



# PD3.1 USB TYPE-C PROTOCOL CONTROLLER HYC5305

REVISION 0.3

DOCUMENTATION NUMBER:  
DS\_HYC5305\_R0.3

---

R0.3

Page 1 of 16

## Table of Contents

1	Features .....	3	7.4	NTC Protection .....	10
2	Applications.....	3	7.5	Over Voltage Protection .....	10
3	Description .....	3	7.6	OCP and short protection .....	10
4	Pin Configurations and Function Descriptions ...	4	8	Typical Application Circuit .....	11
5	Specification.....	5	8.1	AC/DC - OPTO feedback .....	11
5.1	Absolute Maximum Ratings.....	5	8.2	DC/DC - FB feedback .....	12
5.2	Recommended Operating Conditions .....	5	9	Mechanical, Packaging & Orderable Info .....	13
5.3	Electrical Characteristics .....	6	9.1	Package Outline: SSOP-10L .....	13
6	Function Description.....	8	9.2	Ordering Information.....	14
6.1	Overview .....	8	9.3	Tape and Reel Information .....	14
6.2	Function Block.....	8	9.4	Marking and Date Code Information .....	14
7	Application Notes .....	9	10	Revision History.....	15
7.1	VIN PIN & VBUS PIN.....	9	11	Important Notice .....	16
7.2	Constant Voltage and Constant Current ....	9	12	Contact Information .....	16
7.3	Line-Drop compensation.....	10			

## List of Figures

Fig. 1.	Typical Application Schematic .....	3
Fig. 2.	Packages Top View.....	4
Fig. 3.	Function Block.....	8
Fig. 4.	OPTO Feedback .....	9
Fig. 5.	NTC Protection.....	10
Fig. 6.	Application for ACDC .....	11
Fig. 7.	Application for DCDC .....	12
Fig. 8.	Package Outline.....	13

## List of Tables

Table 1.	Pin Function Descriptions.....	4
Table 2.	Absolute Maximum Ratings .....	5
Table 3.	Recommended Operating Conditions .....	5
Table 4.	Electrical Characteristics .....	6
Table 5.	OPTO feedback Application BOM list .....	11
Table 6.	FB feedback Application BOM list .....	12

## Type-C PD3.1 / PPS Protocol Controller

### 1 Features

- USB PD3.1 SPR with PPS certified, **TID 9557**
- USB Type-C 2.2 and USB PD 3.1 / 2.0 Compliant
  - Support 5V, 9V, 12V, 15V and 20V FPDOs
  - Support 2 programmable APDOs
  - Support USB Type-C 2.2 DFP
- Safety Integration
  - Over voltage protection
  - Over current protection
  - Output short protection
  - Over-temperature Protection
  - CC1 / CC2 overvoltage protection
  - NTC
  - UVLO
- Integration 25 mΩ R<sub>DS(on)</sub> N-MOSFET
- Support external 5 mΩ current sense
- Integration discharge
- Programable Cable drop compensation
- Support Constant Current and Constant Voltage Loop
- Adaptive power control by Temperature
- Support Online Update
- HBM ESD ±4 kV rating for all pins
- SSOP-10L

### 2 Applications

- Adaptor
- Power Strip

### 3 Description

The HYC5305 is a high performance, high integration USB Type-C Power Delivery Source Controller. The HYC5305 supporting 5 FPDOs and 2 APDOs with programmable current and voltage which are fully compliant with USB Power Delivery Specification Revision 3.1, Version 1.8.

The HYC5305 integrates a 25 mΩ R<sub>DS(on)</sub> N-MOSFET to enable the VBUS from VIN to protect the devices connected with VBUS.

The HYC5305 integrates perfect protection such as Over Voltage Protection (OVP), Under Voltage Lockout (UVLO), Over Current Protection (OCP), output short protection, CC Over Voltage Protection and Over-temperature Protection.

The HYC5305 is available SSOP-10L package.

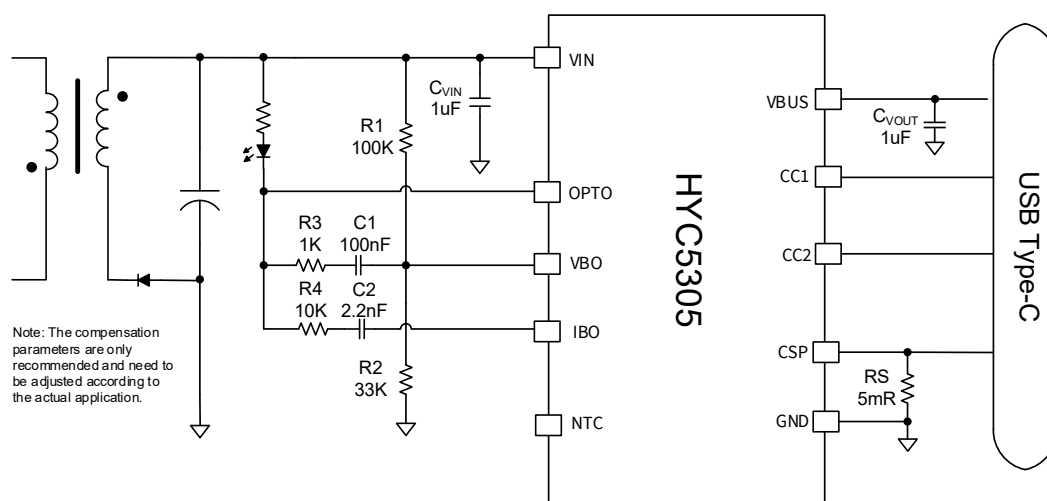
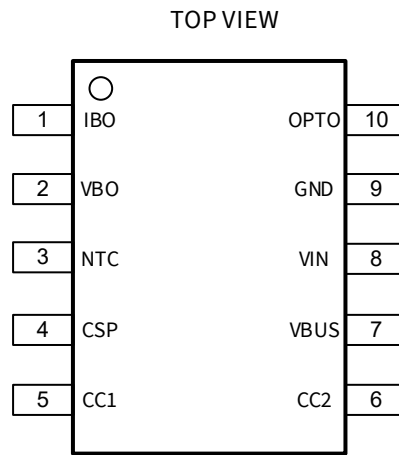

Fig. 1. Typical Application Schematic

## 4 Pin Configurations and Function Descriptions



SSOP-10L

Fig. 2. Packages Top View

Table 1. Pin Function Descriptions

Pin	Name	Description
1	IBO	Current feedback compensation
2	VBO	Output voltage feedback and compensation
3	NTC	An external negative temperature coefficient resistor connected to this pin for remote temperature sensing
4	CSP	Current detection positive point
5	CC1	Configuration channel interface pin to USB Type-C
6	CC2	Configuration channel interface pin to USB Type-C
7	VBUS	Internal N-MOSFET Source and the VBUS voltage sense, connected to USB Type-C VBUS
8	VIN	Internal N-MOSFET Drain, power supply for internal circuits and the input voltage sense, connect a 1 uF capacitor from this pin to GND
9	GND	Ground
10	OPTO	Optical coupler

## 5 Specification

### 5.1 Absolute Maximum Ratings

Table 2. Absolute Maximum Ratings

Parameter	Min	Max	Unit
VBO, IBO, CSP, NTC	-0.3	6.5	V
VIN, VBUS, OPTO, CC1, CC2	-0.3	28	V
Junction Temperature Range	-40	125	°C
Ambient Temperature Range	-40	85	°C
Storage Temperature Range	-55	150	°C
Lead Temperature Range (Soldering 10 sec)		260	°C
ESD Human Body Model (100pF Capacitance, Series 1.5KΩ)	-4000	+4000	V

Note: Exceeding the specified limits for the operating conditions of the device can result in permanent damage to the device. The parameters provided are only the limit values for the operating conditions, and operating the device outside of the recommended working conditions is not advisable. The device's reliability may be affected by prolonged operation under extreme conditions.

### 5.2 Recommended Operating Conditions

Table 3. Recommended Operating Conditions

Parameter	Min	Max	Unit
Input Voltage VIN	3	24	V
Junction Temperature Range	-40	125	°C

### 5.3 Electrical Characteristics

$V_{in} = 5V$ ,  $T_{AMB} = 25^\circ C$  (unless noted otherwise)

Table 4. Electrical Characteristics

Symbol	Parameter	Test Conditions	Min	Typ.	Max	Unit
VIN						
$V_{IN}$	Input Voltage		3		24	V
$V_{IN\_UVLO}$		Rising		3.27		V
$V_{IN\_UVLO\_HYS}$	Input Under-Voltage Lockout (UVLO)			0.2		V
$I_Q$	Input Quiescent Current	CC Locked		2.5		mA
		CC Unlocked		200		uA
VOUT						
$V_{OVP\_TH}$	$V_{OUT} = 5V$	For fixed PDO. For the continuous mode, it will select the threshold based on the range		6		V
	$V_{OUT} = 9V$			10.5		V
	$V_{OUT} = 12V$			13.8		V
	$V_{OUT} = 15V$			17.8		V
	$V_{OUT} = 20V$			24		V
$R_{DS(on)}$ of Internal Switch MOSFET						
$R_{DS(on)}$	Internal N-MOSFET			25		m $\Omega$
Discharge						
$I_{DIS}$	Discharge Current	$V_{OUT} = 20V$			130	mA
$R_{VBUS}$	Bleeding resistor			100		k $\Omega$
Transmitter (CC1, CC2)						
$z_{Driver}$	TX Output Impedance		30	54	70	$\Omega$
$V_{Swing}$	BMC Amplitude		1.050	1.125	1.200	V
$V_{TXLOW}$	Transmit LOW				75	mV
$f_{BitRate}$	BMC Rate		270	300	330	kbps
Receiver (CC1, CC2)						
$V_{RXHI}$	Receiver HIGH	Rising edge		840		mV
$V_{RXLOW}$	Receiver LOW	Falling edge		530		mV
Type-C DFP specification (CC1, CC2)						
$V_{D\_SRC3A}$	Detach threshold when detached in 3A DFP mode	Rising threshold	2.5	2.625	2.75	V
		Hysteresis		0.05		V
$V_{Rd\_SRC3A}$	Ra, Rd detection threshold in 3A mode (falling)	$0V \leq V_{CCx} \leq 2.5V$	0.75	0.79	0.83	V
		Hysteresis		0.02		V
$I_{RP\_SRC}$	CC1/CC2 Broadcasting current	3A DFP, $R_D = 5.1K$	1.6	1.68	1.76	V
$T_{CCDebounce}$	Deglintch filter for UFP attach detection		120	150	180	ms
$T_{PDDebounce}$	Deglintch filter for UFP detach detection		12	15	18	ms
Constant Current						
CC	Constant current point	Configurable				
OCP	Short current protection	$R_{sense} = 5m\Omega$		16		A

Symbol	Parameter	Test Conditions	Min	Typ.	Max	Unit
NTC						
$I_{NTC}$	NTC source current			48		$\mu A$
$V_{NTC\_TH}$	NTC Protection Threshold	Rising		0.6		V
		Falling		0.3		V
$V_{NTC\_HYS}$		Hysterias		0.3		V
OTP						
$T_{J1}$	Over temperature protection	Rising edge		145		$^{\circ}C$
		Hysteresis		20		$^{\circ}C$

## 6 Function Description

### 6.1 Overview

The HYC5305 is a high performance, high integration USB Type-C Power Delivery Source Controller. The HYC5305 supporting 5 FPDOs and 2 APDOs with programmable current and voltage which are fully compliant with USB Power Delivery Specification Revision 3.1, Version 1.8. It is an ideal solution for power supply devices like car chargers and quick charger adapters.

The HYC5305 integrates the CV and CC loop control, to eliminate TL431, so that the BOM is minimized.

The HYC5305 integrated a 25 mΩ load switch MOSFET between VBUS and VIN, so it benefits to PCB Layout.

A current sampling resistor is connected to a 5mΩ alloy resistor on GND and CSP for current sampling.

The output voltage of the HYC5305 has a programmable line compensation function. After the output current increases, the output voltage will be correspondingly increased to compensate for the voltage drop caused by the connection line impedance. For specific configuration requirements, please contact HYASiC.

The HYC5305 has multiple protection functions, including output over-voltage protection, output short circuit protection, data pin short circuit protection, over-current protection and over-temperature protection.

### 6.2 Function Block

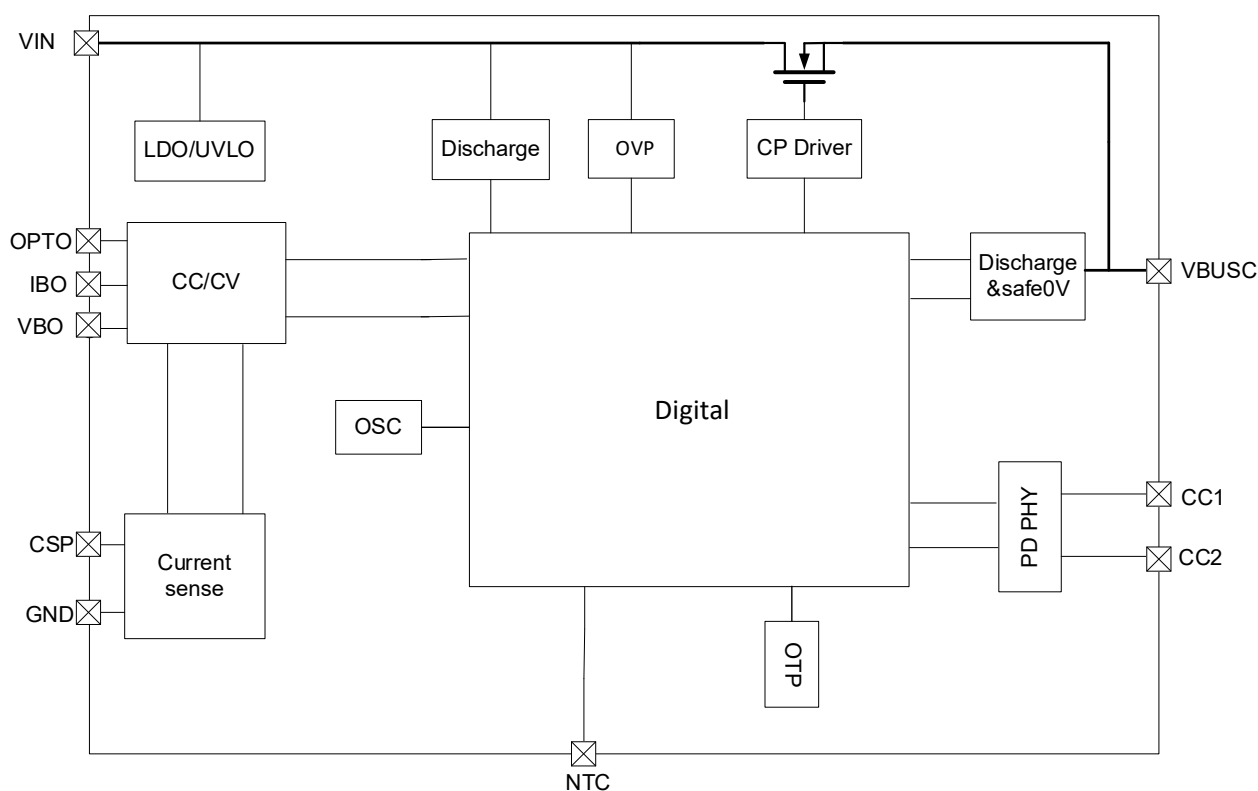

Fig. 3. Function Block

## 7 Application Notes

### 7.1 VIN PIN & VBUS PIN

The VIN pin is the chip's internal power supply input and voltage sense input, connected to the AC-DC or DC-DC output, it is recommended to connect an external 1uF capacitor to GND near this pin. It is also an internal discharge drain pathway. Used to drain the charge stored by the output capacitor of the external AC/DC power supply when the device is removed or the device requests a step-down, so that the voltage is regulated to safe5V or the target voltage. This pin is also the internal N-MOSFET Drain, so we need use copper tie to power out when layout.

The VBUS pin is used to sense the USB Type-C port voltage, and is also used as a USB Type-C port Discharge path, and it is recommended to connect an external 1uF capacitor to GND. This pin is also the internal N-MOSFET Source, so we need use copper tie to USB Type-C VBUS when layout.

### 7.2 Constant Voltage and Constant Current

The HYC5305 integrates CV and CC loop control. As shown in the figure below, CV loop control is realized through VBO and OPTO, where OPTO is connected to an external optocoupler and VBO is connected to a voltage divider network composed of R1 and R2. When the device requests a voltage to step-up or step-down, the HYC5305 feeds back the network node according to sink or source current in 0.2uA/step through VBO. Whether it is VBO feedback or OPTO feedback, R1 must be 100K, R2 is 33K in OPTO feedback applications, and R2 is calculated based on the actual situation of the front-end power supply in FB feedback applications.

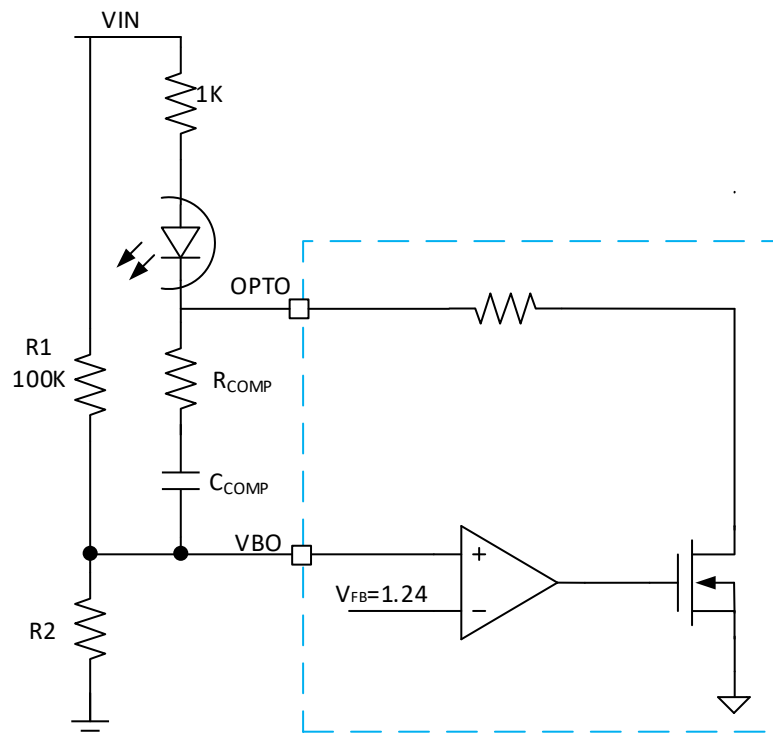

Fig. 4. OPTO Feedback

To suppose the input voltage is VIN, and VBO of the power source is regulated to V<sub>FB</sub>, then there is how to calculate the resistance of R2:

$$R2 = \frac{V_{FB} \times R1}{VIN - V_{FB}}$$

Equation 1

The HYC5305 implements constant current control and current sampling via OPTO, IBO, and GND and CSP with an external sampling resistor of 5mΩ. The sampling resistor should be layout in Kelvin connection, with one end being the CSP and the other end being the GND of the chip. The sampled current information is also used by the HYC5305 to determine whether is over current or short circuit. The compensation network between OPTO and IBO needs to be adjusted for the specified application.

### 7.3 Line-Drop compensation

The Built-in line drop compensation function of the HYC5305 has programmable compensation coefficient to meet different application, according to output current. The HYC5305 currently supports five types of line drop compensation coefficients: 0mV/A, 50mV/A, 100mV/A, 150mV/A, 200mV/A. The default configuration is 100mV/A.

### 7.4 NTC Protection

The HYC5305 uses the NTC pin to sense the external temperature. As show in Fig.5, there is an internal current source 48 μA at the NTC pin. With an external NTC resistor from NTC pin to ground, the HYC5305 can detect the voltage across this NTC resistor and calculate the temperature per the T-R characteristics. When the NTC PIN is used to power reduction function, the threshold is 0.6V, when it used to protection function, the rising threshold is 0.6V and the falling threshold 0.3V.

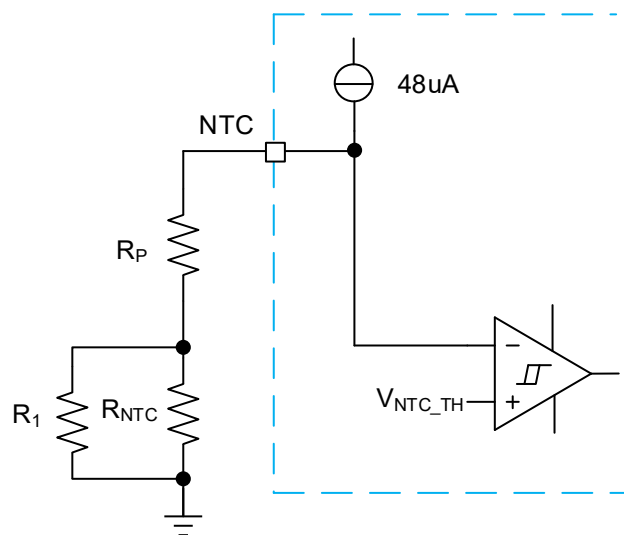

Fig. 5. NTC Protection

### 7.5 Over Voltage Protection

The HYC5305 supports OVP by monitoring the voltage of VIN pin, once the voltage exceeds the over voltage threshold of the required the OVP procedure will be triggered, and then the HYC5305 turns off internal NMOS FET quickly.

### 7.6 OCP and short protection

The HYC5305 monitors output current through the external 5mΩ sense resistor connected to CSP and GND for over current and short-circuit protection. When the output current exceeds the over current protection threshold or short-circuit protection threshold corresponding to the requested, the over current or short-circuit protection procedure is triggered, and then the HYC5305 turns off internal NMOS FET quickly.

## 8 Typical Application Circuit

### 8.1 AC/DC - OPTO feedback

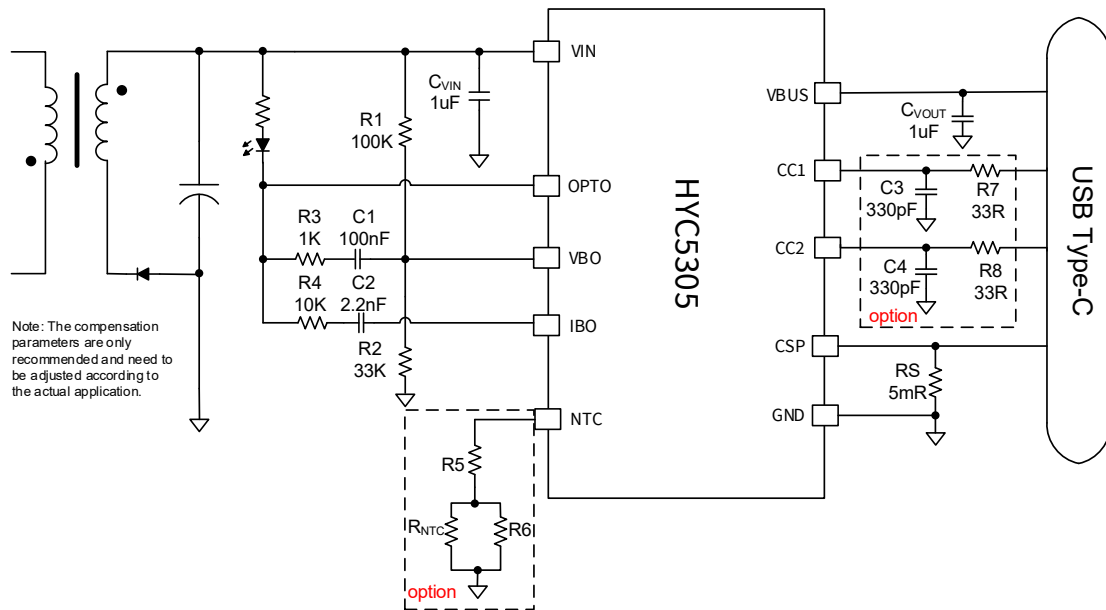

Fig. 6. Application for ACDC

Note: Must using Kelvin Connect to connect current sense resistor RS.

Table 5. OPTO feedback Application BOM list

No.	Part Name	Description	Unit	Qty	Location
1	IC	HYC5305	PCS	1	
2	SMD capacitor	0603, 1uF, +/-20%, 25V, X5R	PCS	2	C <sub>VIN</sub> , C <sub>OUT</sub>
3	SMD capacitor	0603, 100nF, +/-20%, 25V, X5R	PCS	1	C1
4	SMD capacitor	0603, 2.2nF, +/-20%, 25V, X5R	PCS	1	C2
5	SMD resistor	0603, 330pF, +/-20%, 50V, X5R, for option	PCS	2	C3, C4
6	SMD resistor	0603, 100K, 1%	PCS	1	R1
7	SMD resistor	0603, 33K, 1%	PCS	1	R2
8	SMD resistor	0603, 1K, 5%	PCS	1	R3
9	SMD resistor	0603, 10K, 5%	PCS	1	R4
10	SMD resistor	1206, 5mohm, 1%, temperature coefficient less than 100ppm	PCS	1	RS
11	SMD resistor	0603, 33R, 5%, for option	PCS	2	R7, R8

## 8.2 DC/DC - FB feedback

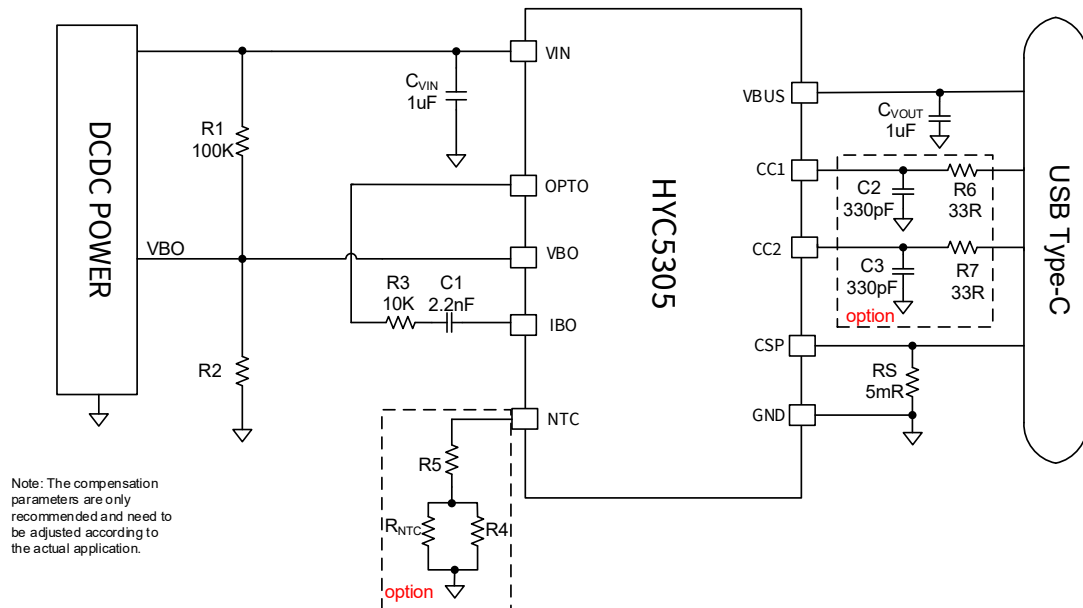

Fig. 7. Application for DCDC

Note: Must using Kelvin Connect to connect current sense resistor R5.

Table 6. FB feedback Application BOM list

No.	Part Name	Description	Unit	Qty	Location
1	IC	HYC5305	PCS	1	
2	SMD capacitor	0603, 1uF, +/-20%, 25V, X5R	PCS	2	C <sub>VIN</sub> , C <sub>OUT</sub>
3	SMD capacitor	0603, 2.2nF, +/-20%, 25V, X5R	PCS	1	C1
4	SMD resistor	0603, 330pF, +/-20%, 50V, X5R, for option	PCS	2	C2, C3
5	SMD resistor	0603, 100K, 1%	PCS	1	R1
6	SMD resistor	Calculated by FB voltage of VIN power	PCS	1	R2
7	SMD resistor	0603, 10K, 5%	PCS	1	R3
8	SMD resistor	1206, 5mohm, 1%, temperature coefficient less than 100ppm	PCS	1	R5
9	SMD resistor	0603, 33R, 5%, for option	PCS	2	R6, R7

## 9 Mechanical, Packaging & Orderable Info

### 9.1 Package Outline: SSOP-10L

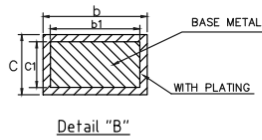
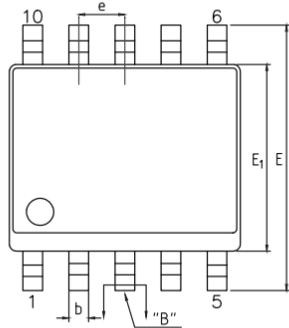

SYMBOL	DIMENSION IN MM		
	MIN	NOM	MAX
A	---	---	1.75
A1	0.10	---	0.225
A2	1.30	1.40	1.50
A3	0.60	0.65	0.70
b	0.23	---	0.30
b1	0.22	0.25	0.28
c	0.20	---	0.24
c1	0.19	0.20	0.21
D	4.80	4.90	5.00
E	5.80	6.00	6.20
E1	3.80	3.90	4.00
e	1.0750BSC		
h	0.25	---	0.50
L	0.50	---	0.80
L1	1.05REF		
⌀	0°	---	8°

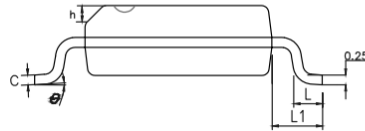
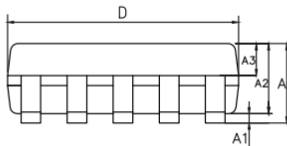

SSOP-10L

Fig. 8. Package Outline

### 9.2 Ordering Information

Part Number	Configuration	Package	MOD
HYC5305B20001S	FPDO:5V/3A,9V/2.22A,12V/1.67A	SSOP-10L	4K/Reel
	PPS:3.3-5.9V/3A,3.3-11V/2A		
	Line drop compensation:100mV/A		
	OCP:110%		
HYC5305D30001S	FPDO:5V/3A,9V/3A,12V/2.5A,15V/2A,20V/1.5A	SSOP-10L	4K/Reel
	PPS:3.3-11V/3A,3.3-16V/2A		
	Line drop compensation:100mV/A		
	OCP:110%		
HYC5305XXXXXX	For part numbers not listed above, please contact Hyasic		

### 9.3 Tape and Reel Information

Package Type	PCs/Reel	Reel/Reel Box	Reel Box/Carton Box	PCs/Carton Box
SSOP-10L	4K	2	8	64K

### 9.4 Marking and Date Code Information



XXXXXXX  
Product Number  
A BC XX  
Year Code Week Code Internal Code

Year		Year Code
2009	2024	A
2010	2025	B
2011	2026	C
2012	2027	D
2013	2028	E
2014	2029	F
2015	2030	G
2016	2031	H
2017	2032	J
2018	2033	K
2019	2034	L
2020	2035	M
2021	2036	N
2022	2037	P
2023	2038	Q

## 10 Revision History

Revision	Date	Changes
0.1	2024-03-23	Initial datasheet
0.2	2024-04-09	R <sub>DS(on)</sub> changes from 30 mΩ to 25 mΩ
0.3	2024-08-30	Update Tape and Reel Information

## 11 Important Notice

HYASiC Inc. reserves the right to make corrections, enhancements, improvements and other changes to its semiconductor products and this document. This document is confidential and is for the use of the intended customer only. Any disclosure, copying or distribution of this datasheet without the explicit agreement of HYASiC Inc. is strictly prohibited.

## 12 Contact Information