

型号 Model: TFF-M10VA

电压 Voltage: 1.5-24V

转速 Speed: 2000-3000rpm

应用领域 Application Fields: 机器人 Robots, 电子门锁 Lockset,
玩具 Toys, 家电 Appliances,
办公设备 Office equipments.



外型尺寸/DRAWING(mm)

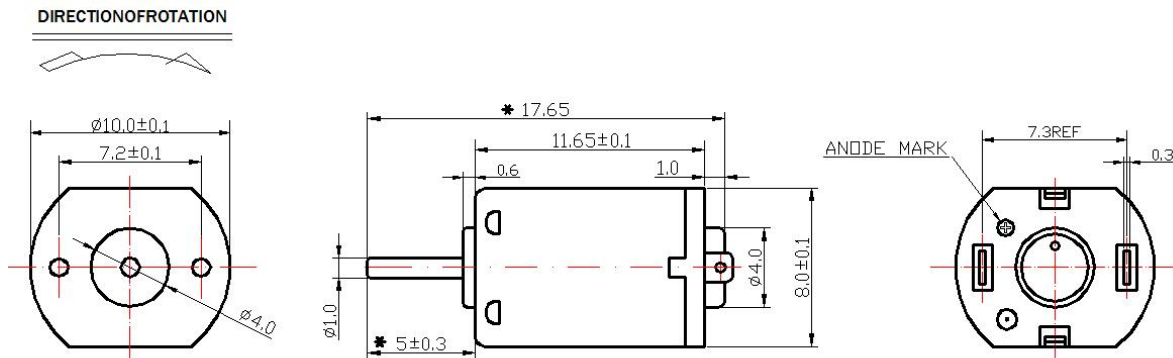

电机参数/Motor Data:

型号 Model	始动电压 Start voltage	额定电压 Rated voltage	空载转速 No Load Speed	空载电流 No Load current	负载 Load	负载转速 Load Speed	负载电流 load current	堵转力矩 Stall torque	功率 Power
	V	V	rpm	A	g.cm	rpm	A	g.cm	W
TFF-M10VA-07200	1.0	3.0	16000	0.058	2.0	7800	0.2	4.5	0.25
TFF-M10VA-06200	1.2	3.0	12100	0.043	1.5	9566	0.086	7.0	0.22

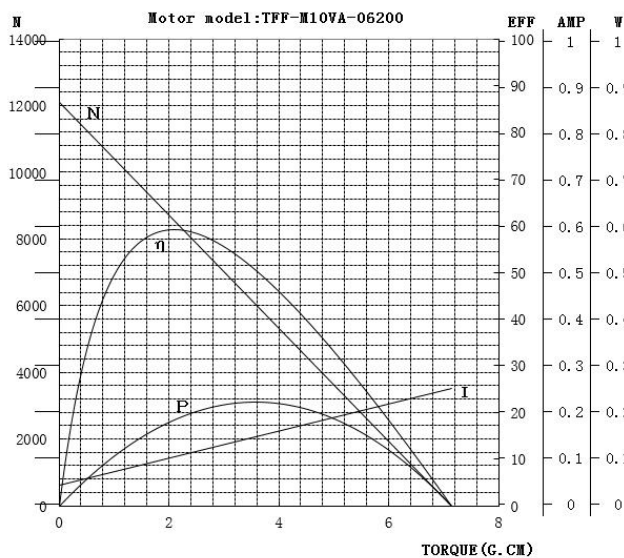

备注 Remarks

- 电机测试环境温度 常温 25-30°C
Ambient temperature 25-30°C
- 外型图中带*尺寸可按客户要求调整。
Dimension with * in the drawing can be adjusted according to customer's requirement.
- 可按客户要求性能, 安装, 电源连接方式, 外型尺寸的设计。
Motor can be designed upon customer's requirements on performance, installation, power connection method and motor dimension.

1inch=25.4mm 1mm=0.0394inch
1g.cm=0.098mN.m 1mN.m=10.2g.cm

型号 Model: TFF-M10VAZ

电压 Voltage: 1.5-24V

转速 Speed: 2000-15000rpm

应用领域 Application Fields::

美容产品 Beauty Products, 成人用品 Sex toys,

按摩保健 Massage Equip, 电动牙刷 Electric toothbrush



外型尺寸/DRAWING(mm)

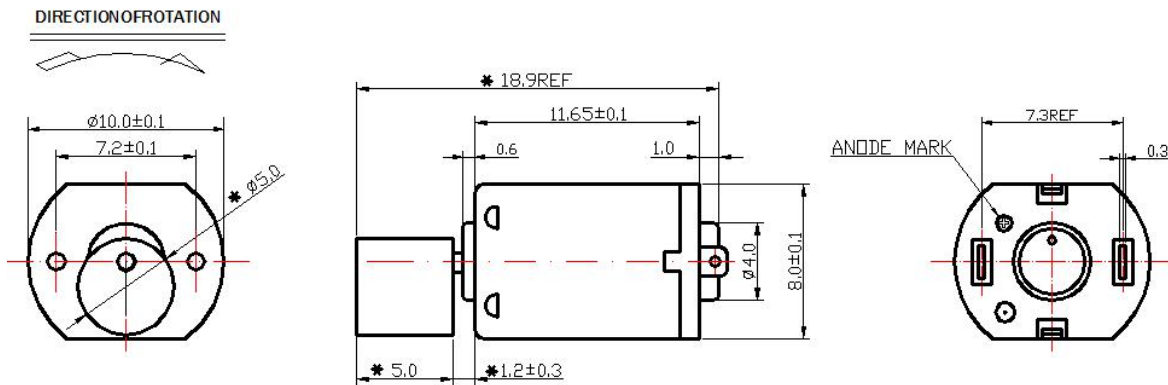

电机参数/MOTOR Data:

型号 Model	始动电压 Start voltage	额定电压 Rated voltage	负载 Load	电流 current	转速 Speed	堵转电流 Lock rotor	功率 Power
	V	V	size	A	rpm	A	W
TFF-M10VAZ-06210	1.2	3.7	ø5*5	0.15	13200	0.28	0.55
TFF-M10VAZ-07155	1.2	3.7	R4.2*4.0	0.42	11500	0.52	0.8

可配置铁,铜,钨等材质及各种形状尺寸的偏心轮
Motor can be mounted with various shape and sizes of eccentric weight which is made of iron,brass or ferro-alloy to become vibration motor.



备注 Remarks

- 电机测试环境温度 常温 25-30°C
Ambient temperature 25-30°C
- 外型图中带*尺寸可按客户要求调整。
Dimension with * in the drawing can be adjusted according to customer's requirement.
- 可按客户要求性能,安装,电源连接方式,外型尺寸的设计。
Motor can be designed upon customer's requirements on performance, installation, power connection method and motor dimension.

1inch=25.4mm

1g.cm=0.098mN.m

1mm=0.0394inch

1mN.m=10.2g.cm

型号 Model: TFF-M20VA

电压 Voltage: 1.5-24V

转速 Speed: 2000-30000rpm

应用领域 Application Fields: 机器人 Robots, 电子门锁 Lockset, 玩具 Toys, 家电 Appliances, 办公设备 Office equipments.

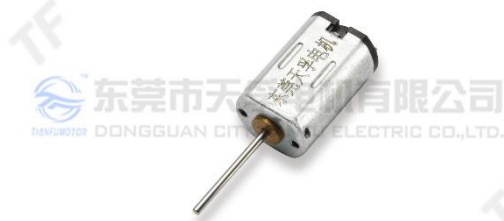

外型尺寸/DRAWING(mm)

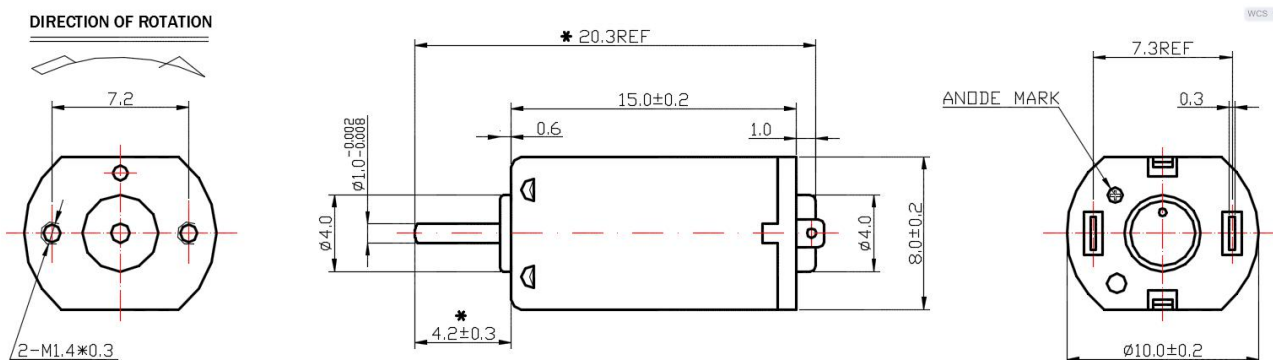

电机参数/Motor Data:

型号 Model	始动电压 Start voltage	额定电压 Rated voltage	空载转速 No Load Speed	空载电流 No Load current	负载 Load	负载转速 Load Speed	负载电流 load current	堵转力矩 Stall torque	功率 Power
	V	V	rpm	A	g.cm	rpm	A	g.cm	W
TFF-M20VA-07180	1.0	3.0	10800	0.035	1.0	8200	0.08	4.0	0.12
TFF-M20VA-08140	1.2	3.0	13000	0.050	2.0	9566	0.140	7.0	0.16

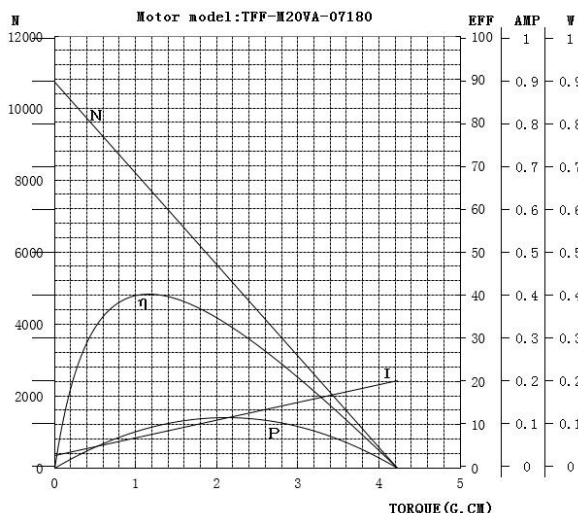

备注 Remarks

- 电机测试环境温度 常温 25-30°C
Ambient temperature 25-30°C
- 外型图中带*尺寸可按客户要求调整。
Dimension with * in the drawing can be adjusted according to customer's requirement.
- 可按客户要求性能,安装,电源连接方式,外型尺寸的设计。
Motor can be designed upon customer's requirements on performance, installation, power connection method and motor dimension.

1inch=25.4mm 1mm=0.0394inch
1g.cm=0.098mN.m 1mN.m=10.2g.cm

型号 Model: TFF-M20VAZ

电压 Voltage: 1.5-24V

转速 Speed: 2000-15000rpm

应用领域 Application Fields::

美容产品 Beauty Products, 成人用品 Sex toys,

按摩保健 Massage Equip, 电动牙刷 Electric toothbrush



外型尺寸/DRAWING(mm)

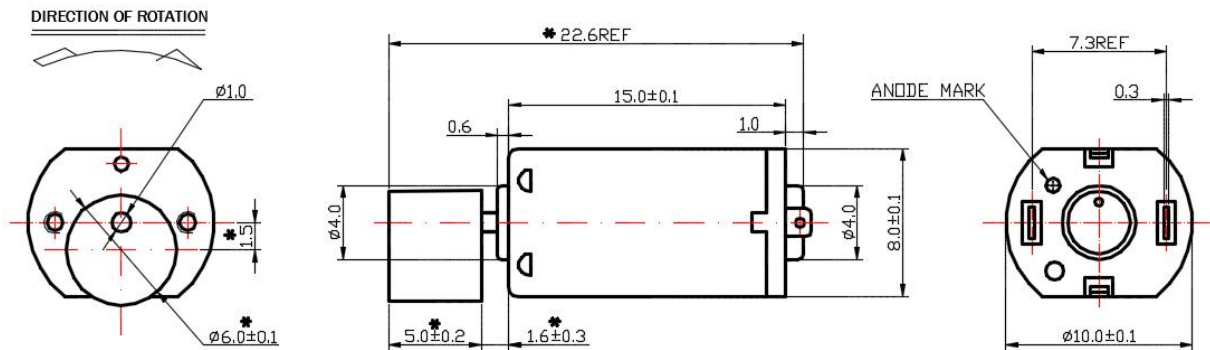

电机参数/MOTOR Data:

型号 Model	始动电压 Start voltage	额定电压 Rated voltage	负载 Load	电流 current	转速 Speed	堵转电流 Lock rotor	功率 Power
	V	V	size	A	rpm	A	W
TFF-M20VAZ-06210	1.2	3.7	ø5*5.0	0.15	13200	0.28	0.55
TFF-M20VAZ-07180	1.2	3.7	R4.2*3.5	0.15	10000	0.15	0.25

可配置铁,铜,钨等材质及各种形状尺寸的偏心轮
Motor can be mounted with various shape and sizes of eccentric weight which is made of iron,brass or ferro-alloy to become vibration motor.



备注 Remarks

- 电机测试环境温度 常温 25-30℃
Ambient temperature 25-30℃
- 外型图中带*尺寸可按客户要求调整。
Dimension with * in the drawing can be adjusted according to customer's requirement.
- 可按客户要求进行性能,安装,电源连接方式,外型尺寸的设计。
Motor can be designed upon customer's requirements on performance, installation,power connection method and motor dimension.

1inch=25.4mm

1mm=0.0394inch

1g.cm=0.098mN.m

1mN.m=10.2g.cm

型号 Model: TFF-1012VA

电压 Voltage: 1.5-24V

转速 Speed: 2000-30000rpm

应用领域 Application Fields: 机器人 Robots, 电子门锁 Lockset,
玩具 Toys, 家电 Appliances,
办公设备 Office equipments.



外型尺寸/DRAWING(mm)

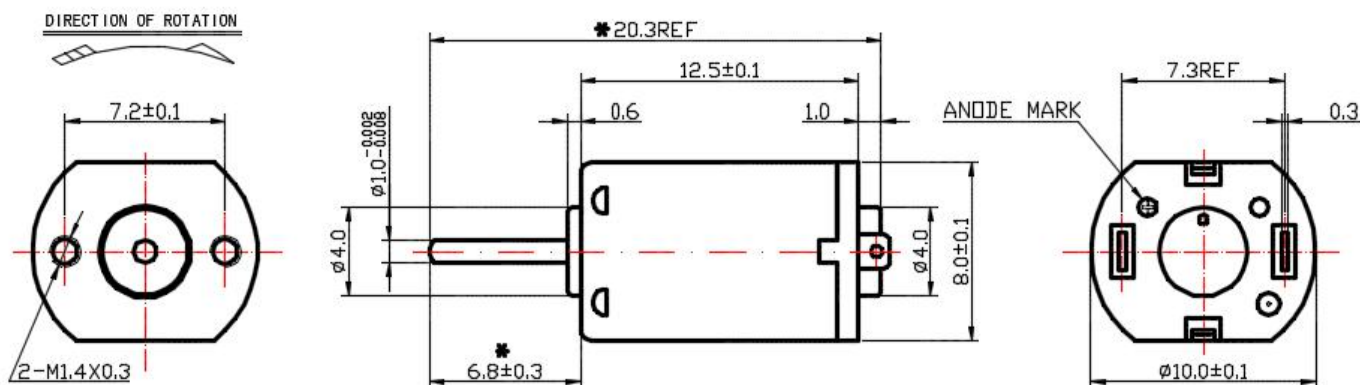

电机参数/Motor Data:

型号 Model	始动电压 Start voltage	额定电压 Rated voltage	空载转速 No Load Speed	空载电流 No Load current	负载 Load	负载转速 Load Speed	负载电流 load current	堵转力矩 Stall torque	功率 Power
	V	V	rpm	A	g.cm	rpm	A	g.cm	W
TFF-1012VA-06215	1.5	6.0	24150	0.035	3.0	13260	0.190	6.0	0.42
TFF-1012VA-09125	1.2	5.0	35000	0.120	4.0	25000	0.450	11.0	1.08

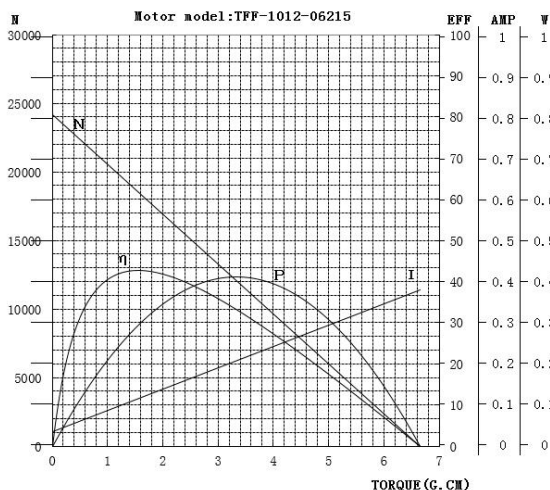

备注 Remarks

- 电机测试环境温度 常温 25-30°C
Ambient temperature 25-30°C
- 外型图中带*尺寸可按客户要求调整。
Dimension with * in the drawing can be adjusted according to customer's requirement.
- 可按客户要求进行性能,安装,电源连接方式,外型尺寸的设计。
Motor can be designed upon customer's requirements on performance, installation, power connection method and motor dimension.

1inch=25.4mm 1mm=0.0394inch
1g.cm=0.098mN.m 1mN.m=10.2g.cm

型号 Model: TFF-1012VAZ

电压 Voltage: 1.5-24V

转速 Speed: 2000-15000rpm

应用领域 Application Fields::

美容产品 Beauty Products, 成人用品 Sex toys,
按摩保健 Massage Equip, 电动牙刷 Electric toothbrush



外型尺寸/DRAWING(mm)

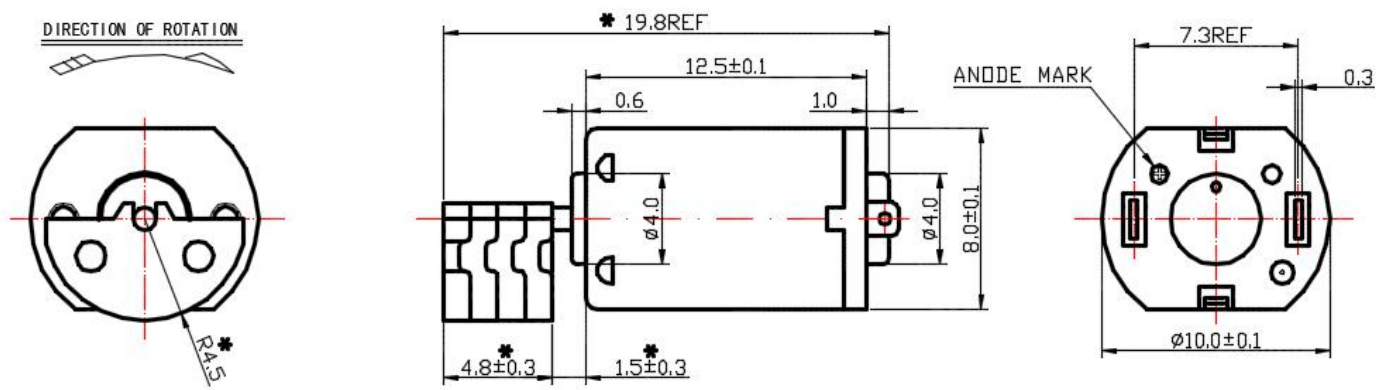

电机参数/MOTOR Data:

型号 Model	始动电压 Start voltage	额定电压 Rated voltage	负载 Load	电流 current	转速 Speed	堵转电流 Lock rotor	功率 Power
	V	V	size	A	rpm	A	W
TFF-1012VAZ-06195	1.2	3.0	φ6*4.0	0.07	10500	0.22	0.35
TFF-1012VAZ-07150	1.5	3.7	R3.0*5.0	0.25	13500	0.60	0.8

可配置铁,铜,钨等材质及各种形状尺寸的偏心轮
Motor can be mounted with various shape and sizes of eccentric weight which is made of iron,brass or ferro-alloy to become vibration motor.



备注 Remarks

- 电机测试环境温度 常温 25-30℃
Ambient temperature 25-30℃
- 外型图中带*尺寸可按客户要求调整。
Dimension with * in the drawing can be adjusted according to customer's requirement.
- 可按客户要求进行性能,安装,电源连接方式,外型尺寸的设计。
Motor can be designed upon customer's requirements on performance, installation,power connection method and motor dimension.

1inch=25.4mm 1mm=0.0394inch
1g.cm=0.098mN.m 1mN.m=10.2g.cm

型号 Model: TFF-N10VA

电压 Voltage: 1.5-24V

转速 Speed: 2000-3000rpm

应用领域 Application Fields: 机器人 Robots, 电子门锁 Lockset,
玩具 Toys, 家电 Appliances,
办公设备 Office equipments.



外型尺寸/DRAWING(mm)

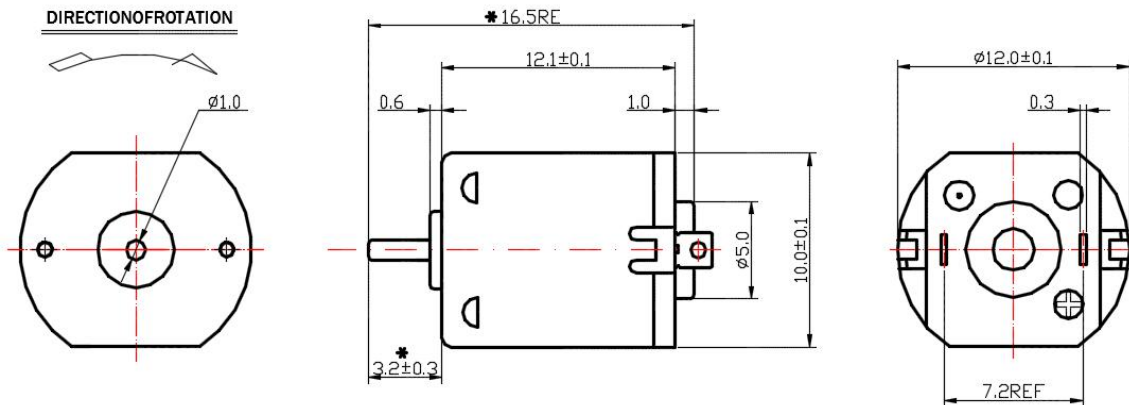

电机参数/Motor Data:

型号 Model	始动电压 Start voltage	额定电压 Rated voltage	空载转速 No Load Speed	空载电流 No Load current	负载 Load	负载转速 Load Speed	负载电流 load current	堵转力矩 Stall torque	功率 Power
	V	V	rpm	A	g.cm	rpm	A	g.cm	W
TFF-N10VA-08225	1.2	3.7	15900	0.045	2.0	11200	0.130	6.0	0.26
TFF-N10VA-06300	1.3	3.3	10256	0.023	2.0	4588	0.095	3.5	0.12

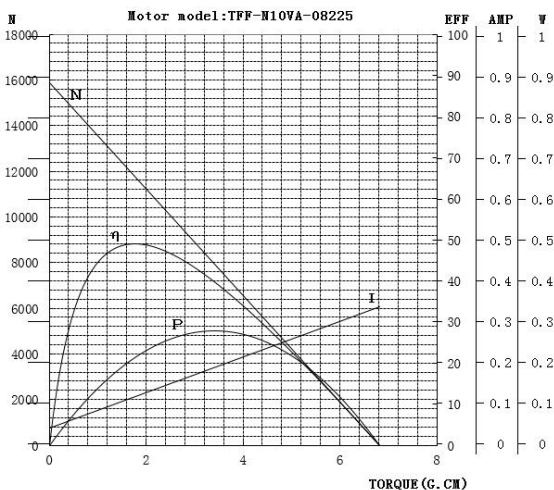

备注 Remarks

- 电机测试环境温度 常温 25-30°C
Ambient temperature 25-30°C
- 外型图中带*尺寸可按客户要求调整。
Dimension with * in the drawing can be adjusted according to customer's requirement.
- 可按客户要求进行性能,安装,电源连接方式,外型尺寸的设计。
Motor can be designed upon customer's requirements on performance, installation, power connection method and motor dimension.

1inch=25.4mm 1mm=0.0394inch
1g.cm=0.098mN.m 1mN.m=10.2g.cm

型号 Model: TFF-N10VAZ

电压 Voltage: 1.5-24V

转速 Speed: 2000-15000rpm

应用领域 Application Fields::

美容产品 Beauty Products, 成人用品 Sex toys,
按摩保健 Massage Equip, 电动牙刷 Electric toothbrush



外型尺寸/DRAWING(mm)

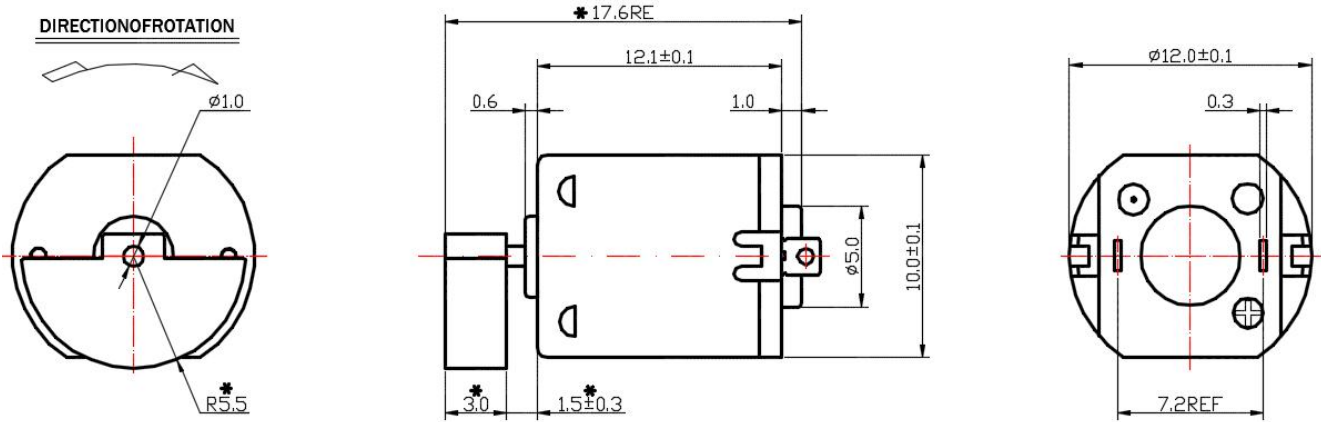

电机参数/MOTOR Data:

型号 Model	始动电压 Start voltage	额定电压 Rated voltage	负载 Load	电流 current	转速 Speed	堵转电流 Lock rotor	功率 Power
	V	V	size	A	rpm	A	W
TFF-N10VAZ-08210	1.2	3.7	R5.5*3.0	0.26	8500	0.45	0.7
TFF-N10VAZ-07250	1.5	3.7	R5.5*3.0	0.21	7300	0.35	0.6

可配置铁,铜,钨等材质及各种形状尺寸的偏心轮
Motor can be mounted with various shape and sizes of eccentric weight which is made of iron,brass or ferro-alloy to become vibration motor.



备注 Remarks

- 电机测试环境温度 常温 25-30℃
Ambient temperature 25-30℃
- 外型图中带*尺寸可按客户要求调整。
Dimension with * in the drawing can be adjusted according to customer's requirement.
- 可按客户要求进行性能,安装,电源连接方式,外型尺寸的设计。
Motor can be designed upon customer's requirements on performance, installation,power connection method and motor dimension.

1inch=25.4mm
1g.cm=0.098mN.m

1mm=0.0394inch
1mN.m=10.2g.cm

型号 Model: TFF-N20VA

电压 Voltage: 1.5-24V

转速 Speed: 2000-30000rpm

应用领域 Application Fields: 机器人 Robots, 电子门锁 Lockset,
玩具 Toys, 家电 Appliances,
办公设备 Office equipments.



外型尺寸/DRAWING(mm)

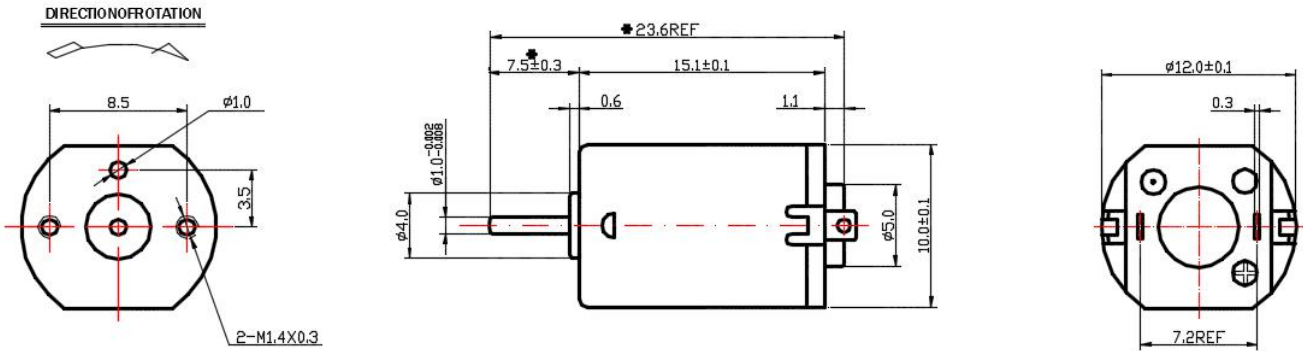

电机参数/Motor Data:

型号 Model	始动电压 Start voltage	额定电压 Rated voltage	空载转速 No Load Speed	空载电流 No Load current	负载 Load	负载转速 Load Speed	负载电流 load current	堵转力矩 Stall torque	功率 Power
	V	V	rpm	A	g.cm	rpm	A	g.cm	W
TFF-N20VA-12115	1.0	3.0	15000	0.045	3	12200	0.214	16	0.6
TFF-N20VA-08200	1.0	5.0	13920	0.030	3	10779	0.125	13	0.57

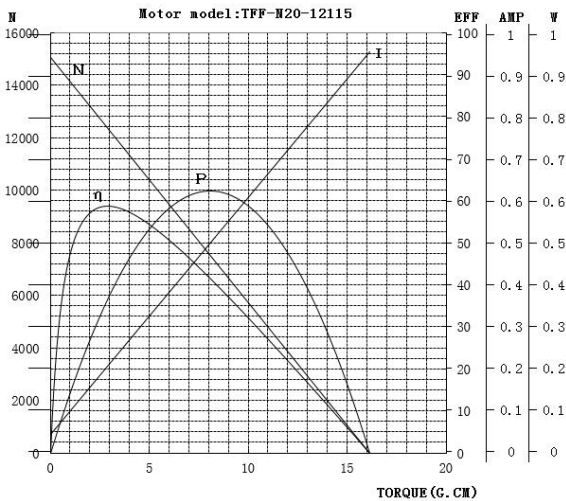

备注 Remarks

- 电机测试环境温度 常温 25-30°C
Ambient temperature 25-30°C
- 外型图中带 * 尺寸可按客户要求调整。
Dimension with * in the drawing can be adjusted according to customer's requirement.
- 可按客户要求进行性能,安装,电源连接方式,外型尺寸的设计。
Motor can be designed upon customer's requirements on performance, installation, power connection method and motor dimension.

1inch=25.4mm 1mm=0.0394inch
1g.cm=0.098mN.m 1mN.m=10.2g.cm

型号 Model: TFF-N20VAZ

电压 Voltage: 1.5-24V

转速 Speed: 2000-15000rpm

应用领域 Application Fields::

美容产品 Beauty Products, 成人用品 Sex toys,
按摩保健 Massage Equip, 电动牙刷 Electric toothbrush



外型尺寸/DRAWING(mm)

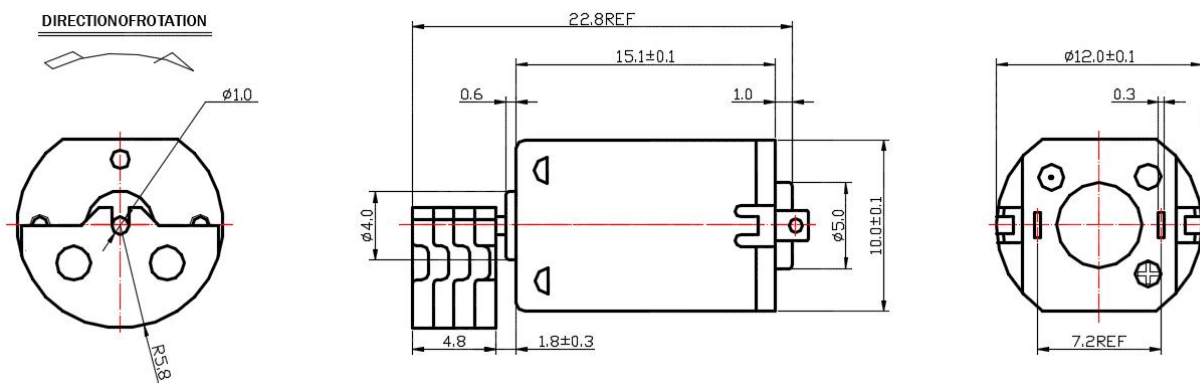

电机参数/MOTOR Data:

型号 Model	始动电压 Start voltage	额定电压 Rated voltage	负载 Load	电流 current	转速 Speed	堵转电流 Lock rotor	功率 Power
	V	V	size	A	rpm	A	W
TFF-N20VAZ-08225	1.2	3.7	R6*4.0	0.11	7600	0.32	0.25
TFF-N20VAZ-09165	1.0	3.7	$\phi 7*5$	0.15	10700	0.5	0.30

可配置铁,铜,钨等材质及各种形状尺寸的偏心轮
Motor can be mounted with various shape and sizes of eccentric weight which is made of iron,brass or ferro-alloy to become vibration motor.

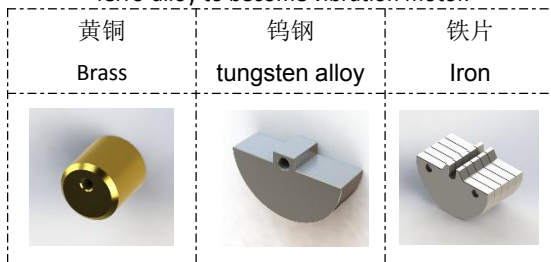

备注 Remarks

- 电机测试环境温度 常温 25-30℃
Ambient temperature 25-30℃
- 外型图中带*尺寸可按客户要求调整。
Dimension with * in the drawing can be adjusted according to customer's requirement.
- 可按客户要求进行性能,安装,电源连接方式,外型尺寸的设计。
Motor can be designed upon customer's requirements on performance, installation, power connection method and motor dimension.

1inch=25.4mm
1g.cm=0.098mN.m

1mm=0.0394inch
1mN.m=10.2g.cm

型号 Model: TFF-N30VA

电压 Voltage: 1.5-24V

转速 Speed: 2000-30000rpm

应用领域 Application Fields: 机器人 Robots, 电子门锁 Lockset,
玩具 Toys, 家电 Appliances,
办公设备 Office equipments.



外型尺寸/DRAWING(mm)

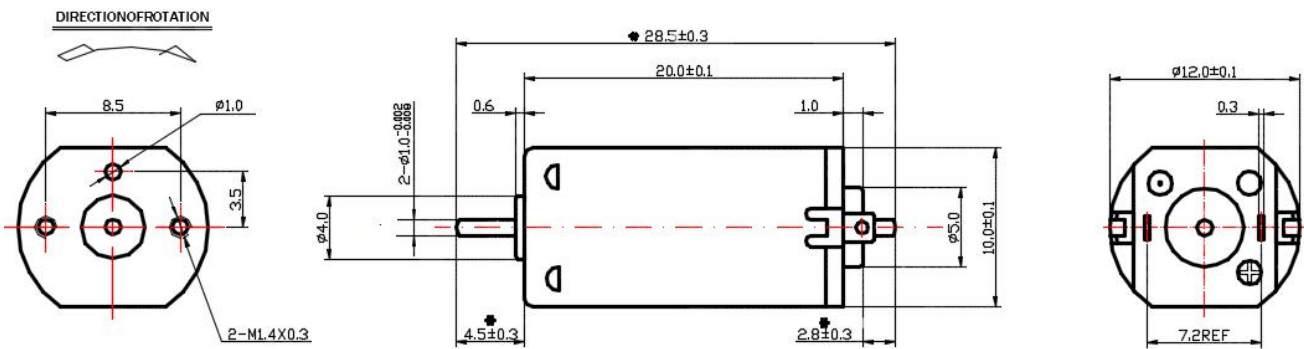

电机参数/Motor Data:

型号 Model	始动电压 Start voltage	额定电压 Rated voltage	空载转速 No Load Speed	空载电流 No Load current	负载 Load	负载转速 Load Speed	负载电流 load current	堵转力矩 Stall torque	功率 Power
	V	V	rpm	A	g.cm	rpm	A	g.cm	W
TFF-N30VA-08235	1.0	6	10200	0.023	3	7780	0.079	12	0.32
TFF-N30VA-12105	1.0	3.0	11200	0.060	5	7300	0.232	15	0.40

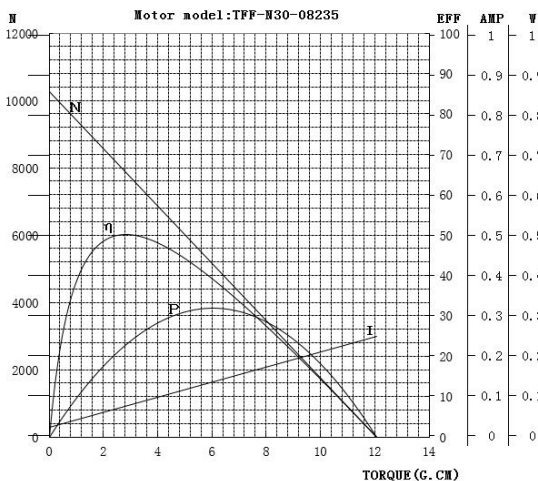

备注 Remarks

- 电机测试环境温度 常温 25-30°C
Ambient temperature 25-30°C
- 外型图中带 * 尺寸可按客户要求调整。
Dimension with * in the drawing can be adjusted according to customer's requirement.
- 可按客户要求进行性能, 安装, 电源连接方式, 外型尺寸的设计。
Motor can be designed upon customer's requirements on performance, installation, power connection method and motor dimension.

1inch=25.4mm 1mm=0.0394inch
1g.cm=0.098mN.m 1mN.m=10.2g.cm

型号 Model: TFF-N30VAZ

电压 Voltage: 1.5-24V

转速 Speed: 2000-15000rpm

应用领域 Application Fields::

美容产品 Beauty Products, 成人用品 Sex toys,
按摩保健 Massage Equip, 电动牙刷 Electric toothbrush



外型尺寸/DRAWING(mm)

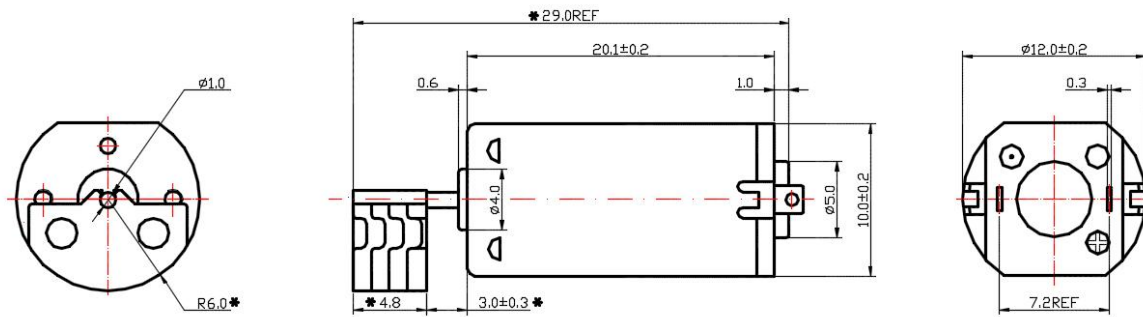

电机参数/MOTOR Data:

型号 Model	始动电压 Start voltage	额定电压 Rated voltage	负载 Load	电流 current	转速 Speed	堵转电流 Lock rotor	功率 Power
	V	V	size	A	rpm	A	W
TFF-N30VAZ-11120	1.2	3.7	R6*4.8	0.26	9500	0.7	0.4
TFF-N30VAZ-1298	1.0	3.7	R6*7.2	0.29	9300	0.96	0.5

可配置铁,铜,钨等材质及各种形状尺寸的偏心轮
Motor can be mounted with various shape and sizes of eccentric weight which is made of iron,brass or ferro-alloy to become vibration motor.

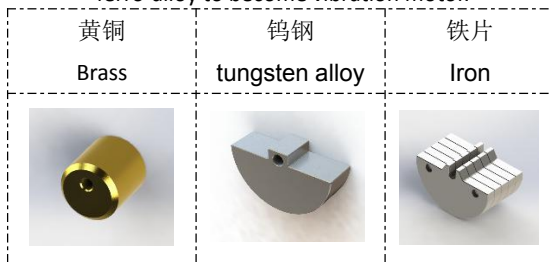

备注 Remarks

- 电机测试环境温度 常温 25-30℃
Ambient temperature 25-30℃
- 外型图中带*尺寸可按客户要求调整。
Dimension with * in the drawing can be adjusted according to customer's requirement.
- 可按客户要求性能,安装,电源连接方式,外型尺寸的设计。
Motor can be designed upon customer's requirements on performance, installation, power connection method and motor dimension.

1inch=25.4mm
1g.cm=0.098mN.m

1mm=0.0394inch
1mN.m=10.2g.cm

型号 Model: TFF-030SB

电压 Voltage: 1.5-24V

转速 Speed: 2000-30000rpm

应用领域 Application Fields: 机器人 Robots, 电子门锁 Lockset,
玩具 Toys, 家电 Appliances,
办公设备 Office equipments.



外型尺寸/DRAWING(mm)

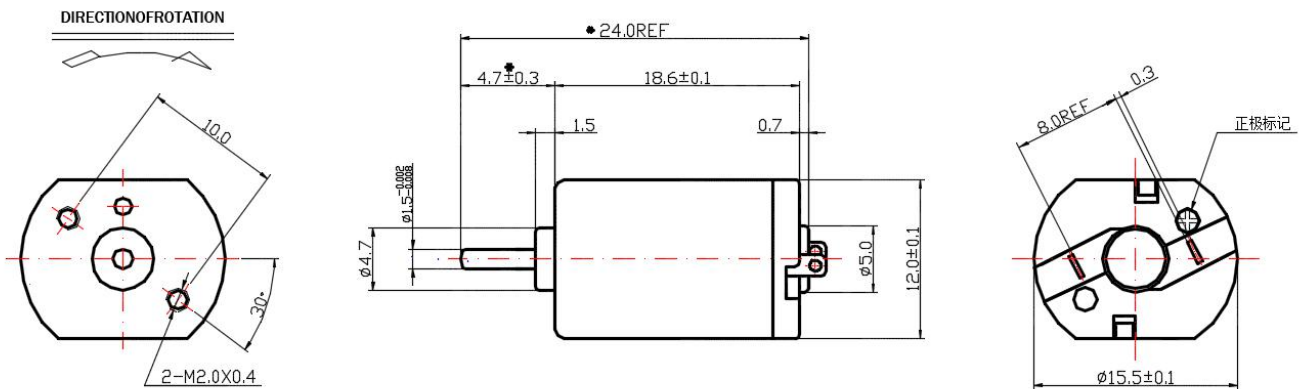

电机参数/Motor Data:

型号 Model	始动电压 Start voltage	额定电压 Rated voltage	空载转速 No Load Speed	空载电流 No Load current	负载 Load	负载转速 Load Speed	负载电流 load current	堵转力矩 Stall torque	功率 Power
	V	V	rpm	A	g.cm	rpm	A	g.cm	W
TFF-030SB-10200	1.0	3.7	6500	0.038	5.0	4800	0.13	19	0.32
TFF-030SB-11160	1.2	12.0	25000	0.081	5.0	22200	0.19	45	1.2

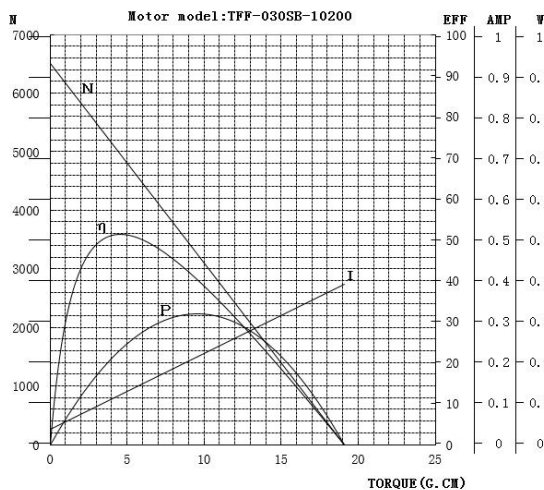

备注 Remarks

- 电机测试环境温度 常温 25-30°C
Ambient temperature 25-30°C
- 外型图中带 * 尺寸可按客户要求调整。
Dimension with * in the drawing can be adjusted according to customer's requirement.
- 可按客户要求进行性能,安装,电源连接方式,外型尺寸的设计。
Motor can be designed upon customer's requirements on performance, installation, power connection method and motor dimension.

1inch=25.4mm 1mm=0.0394inch
1g.cm=0.098mN.m 1mN.m=10.2g.cm

型号 Model: TFF-030SBZ

电压 Voltage: 1.5-24V

转速 Speed: 2000-15000rpm

应用领域 Application Fields::

美容产品 Beauty Products, 成人用品 Sex toys,
按摩保健 Massage Equip, 电动牙刷 Electric toothbrush



外型尺寸/DRAWING(mm)

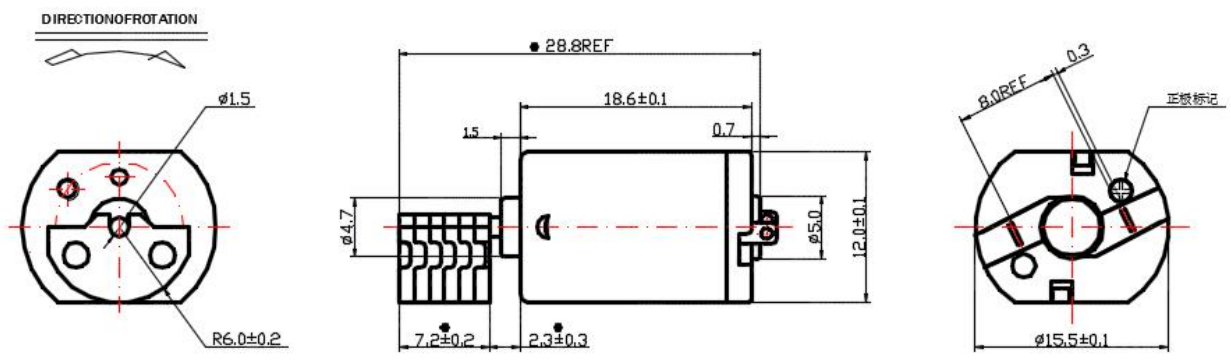

电机参数/MOTOR Data:

型号 Model	始动电压 Start voltage	额定电压 Rated voltage	负载 Load	电流 current	转速 Speed	堵转电流 Lock rotor	功率 Power
	V	V	size	A	rpm	A	W
TFF-030SBZ-12140	1.2	3.7	R6*7.2	0.23	8000	0.87	0.42
TFF-030SBZ-13120	0.7	3.0	R7*6.0	0.30	7100	1.0	0.50

可配置铁,铜,钨等材质及各种形状尺寸的偏心轮
Motor can be mounted with various shape and sizes of eccentric weight which is made of iron,brass or ferro-alloy to become vibration motor.

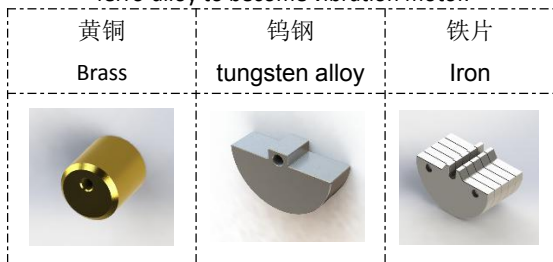

备注 Remarks

- 电机测试环境温度 常温 25-30℃
Ambient temperature 25-30℃
- 外型图中带*尺寸可按客户要求调整。
Dimension with * in the drawing can be adjusted according to customer's requirement.
- 可按客户要求性能,安装,电源连接方式,外型尺寸的设计。
Motor can be designed upon customer's requirements on performance, installation, power connection method and motor dimension.

1inch=25.4mm 1mm=0.0394inch
1g.cm=0.098mN.m 1mN.m=10.2g.cm

型号 Model: TFF-031PA

电压 Voltage: 1.5-24V

转速 Speed: 2000-30000rpm

应用领域 Application Fields: 机器人 Robots, 电子门锁 Lockset,
玩具 Toys, 家电 Appliances,
办公设备 Office equipments.



外型尺寸/DRAWING(mm)

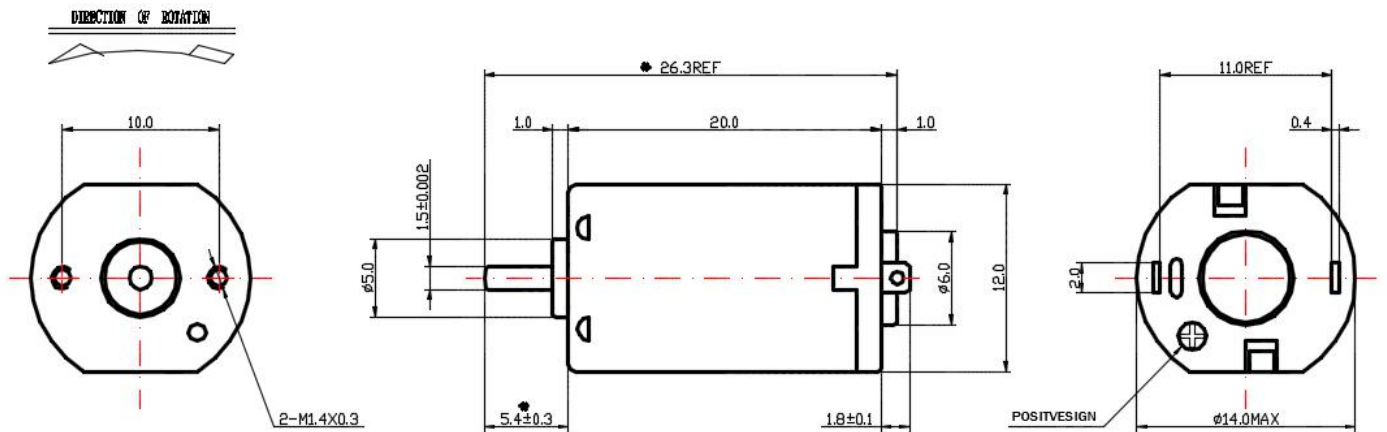

电机参数/Motor Data:

型号 Model	始动电压 Start voltage	额定电压 Rated voltage	空载转速 No Load Speed	空载电流 No Load current	负载 Load	负载转速 Load Speed	负载电流 load current	堵转力矩 Stall torque	功率 Power
	V	V	rpm	A	g.cm	rpm	A	g.cm	W
TFF-031PA-12153	1.5	5	10900	0.042	5	9720	0.155	25	0.7
TFF-031PA-09220	1.5	5	10884	0.042	5	6800	0.120	13	0.37

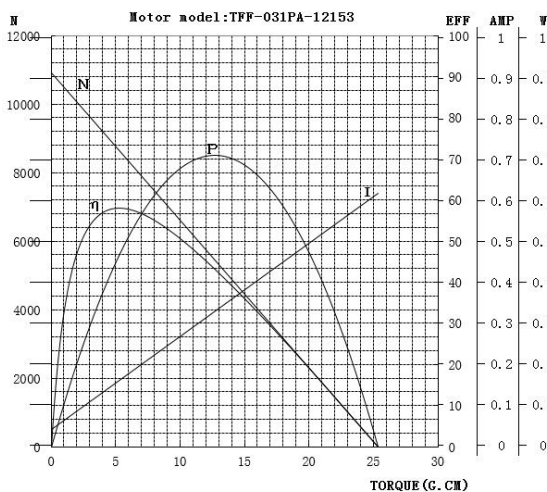

备注 Remarks

- 电机测试环境温度 常温 25-30℃
Ambient temperature 25-30℃
- 外型图中带 * 尺寸可按客户要求调整。
Dimension with * in the drawing can be adjusted according to customer's requirement.
- 可按客户要求进行性能,安装,电源连接方式,外型尺寸的设计。
Motor can be designed upon customer's requirements on performance, installation, power connection method and motor dimension.

1inch=25.4mm 1mm=0.0394inch
1g.cm=0.098mN.m 1mN.m=10.2g.cm

型号 Model: TFF-050SH

电压 Voltage: 1.5-24V

转速 Speed: 2000-30000rpm

应用领域 Application Fields: 机器人 Robots, 电子门锁 Lockset,
玩具 Toys, 家电 Appliances,
办公设备 Office equipments.



外型尺寸/DRAWING(mm)

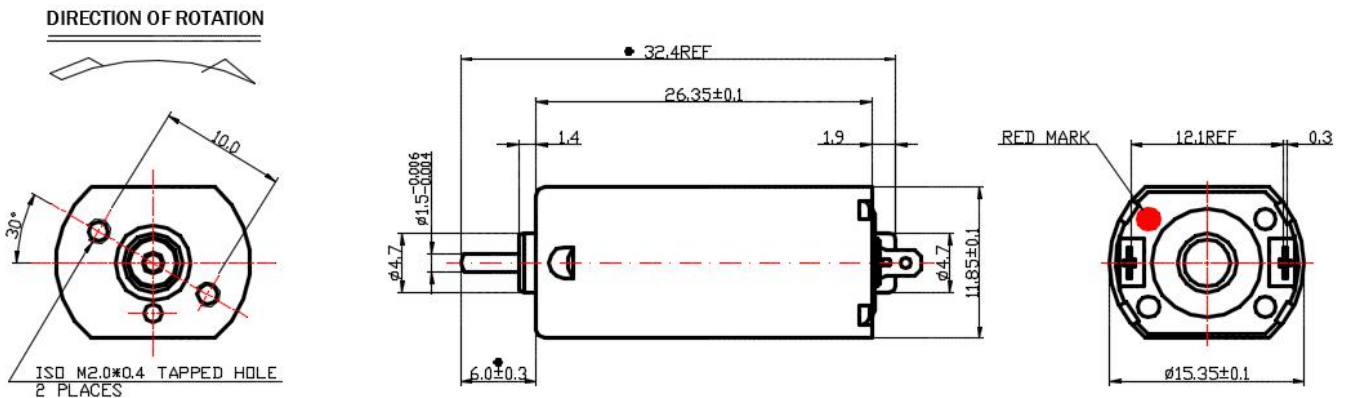

电机参数/Motor Data:

型号 Model	始动电压 Start voltage	额定电压 Rated voltage	空载转速 No Load Speed	空载电流 No Load current	负载 Load	负载转速 Load Speed	负载电流 load current	堵转力矩 Stall torque	功率 Power
	V	V	rpm	A	g.cm	rpm	A	g.cm	W
TFF-050SH-09210	1.6	12	13100	0.071	40	9750	0.222	150	5.2
TFF-050SH-14100	0.8	2.5	5500	0.060	5	4400	0.182	20	0.23

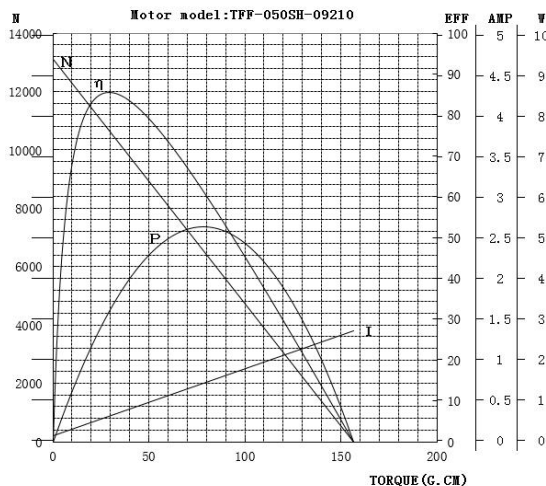

备注 Remarks

- 电机测试环境温度 常温 25-30°C
Ambient temperature 25-30°C
- 外型图中带*尺寸可按客户要求调整。
Dimension with * in the drawing can be adjusted according to customer's requirement.
- 可按客户要求进行性能,安装,电源连接方式,外型尺寸的设计。
Motor can be designed upon customer's requirements on performance, installation, power connection method and motor dimension.

1inch=25.4mm 1mm=0.0394inch
1g.cm=0.098mN.m 1mN.m=10.2g.cm

型号 Model: TFF-050SHZ

电压 Voltage: 1.5-24V

转速 Speed: 2000-15000rpm

应用领域 Application Fields::

美容产品 Beauty Products, 成人用品 Sex toys,
按摩保健 Massage Equip, 电动牙刷 Electric toothbrush



外型尺寸/DRAWING(mm)

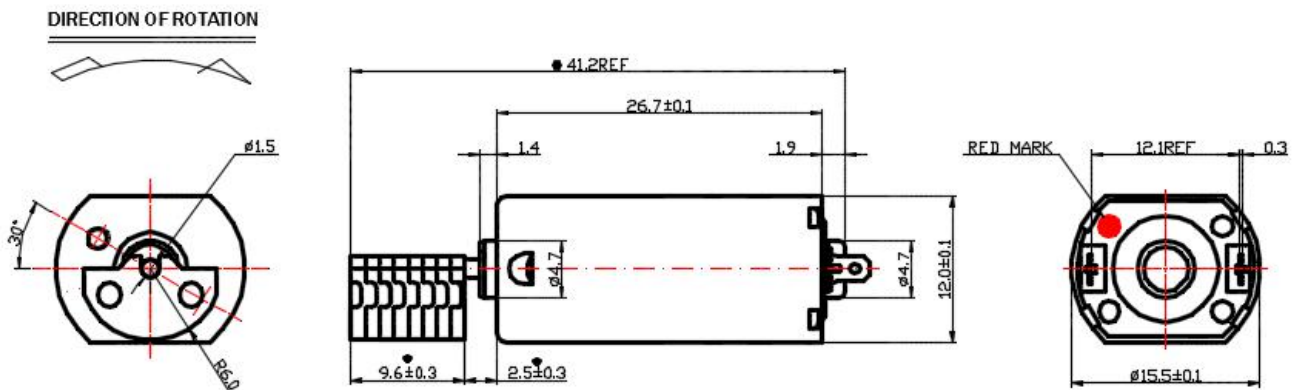

电机参数/MOTOR Data:

型号 Model	始动电压 Start voltage	额定电压 Rated voltage	负载 Load	电流 current	转速 Speed	堵转电流 Lock rotor	功率 Power
	V	V	size	A	rpm	A	W
TFF-050SH-1490	0.8	4.5	Φ8*6.0	0.25	10200	1.45	0.6
TFF-050SH-1780	1.2	3.7	R6.0*9.6	0.42	7700	1.50	0.7

可配置铁,铜,钨等材质及各种形状尺寸的偏心轮
Motor can be mounted with various shape and sizes of eccentric weight which is made of iron,brass or ferro-alloy to become vibration motor.

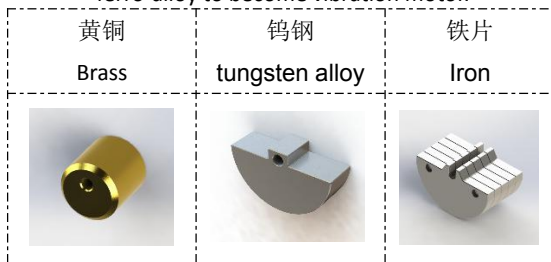

备注 Remarks

- 电机测试环境温度 常温 25-30℃
Ambient temperature 25-30℃
- 外型图中带*尺寸可按客户要求调整。
Dimension with * in the drawing can be adjusted according to customer's requirement.
- 可按客户要求进行性能,安装,电源连接方式,外型尺寸的设计。
Motor can be designed upon customer's requirements on performance, installation,power connection method and motor dimension.

1inch=25.4mm
1g.cm=0.098mN.m

1mm=0.0394inch
1mN.m=10.2g.cm

型号 Model: TFF-130SH

电压 Voltage: 1.5-24V

转速 Speed: 2000-3000rpm

应用领域 Application Fields: 机器人 Robots, 电子门锁 Lockset,
玩具 Toys, 家电 Appliances,
办公设备 Office equipments.



外型尺寸/DRAWING(mm)

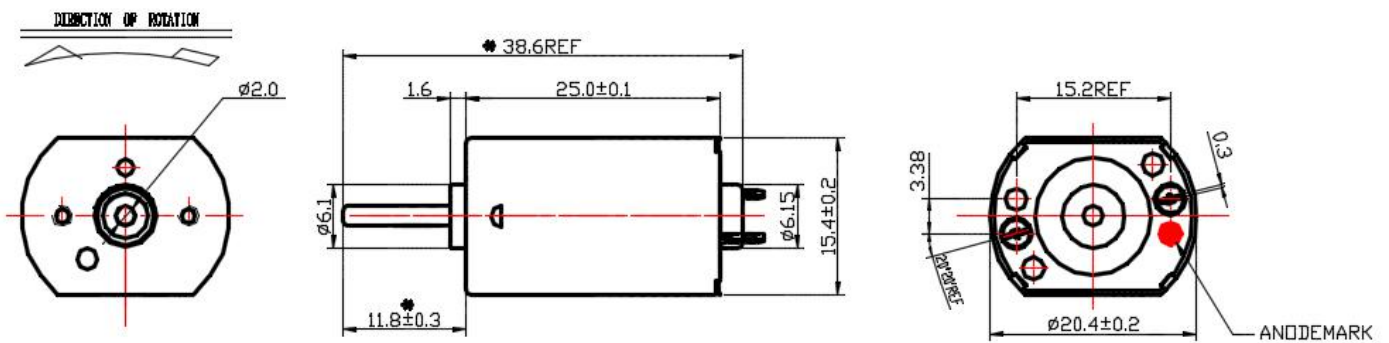

电机参数/Motor Data:

型号 Model	始动电压 Start voltage	额定电压 Rated voltage	空载转速 No Load Speed	空载电流 No Load current	负载 Load	负载转速 Load Speed	负载电流 load current	堵转力矩 Stall torque	功率 Power
	V	V	rpm	A	g.cm	rpm	A	g.cm	W
TFF-130SH-17136	1.0	3.7	7600	0.15	10	6300	0.38	55	1.11
TFF-130SH-05260	3.0	24	7600	0.045	5.0	6000	0.105	25	0.5

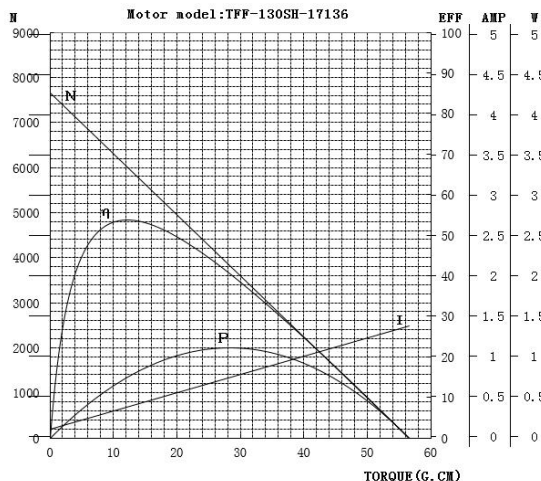

备注 Remarks

- 电机测试环境温度 常温 25-30°C
Ambient temperature 25-30°C
- 外型图中带*尺寸可按客户要求调整。
Dimension with * in the drawing can be adjusted according to customer's requirement.
- 可按客户要求进行性能,安装,电源连接方式,外型尺寸的设计。
Motor can be designed upon customer's requirements on performance, installation, power connection method and motor dimension.

1inch=25.4mm
1g.cm=0.098mN.m

1mm=0.0394inch
1mN.m=10.2g.cm

型号 Model: TFF-130SHZ

电压 Voltage: 1.5-24V

转速 Speed: 2000-15000rpm

应用领域 Application Fields::

美容产品 Beauty Products, 成人用品 Sex toys,
按摩保健 Massage Equip, 电动牙刷 Electric toothbrush



外型尺寸/DRAWING(mm)

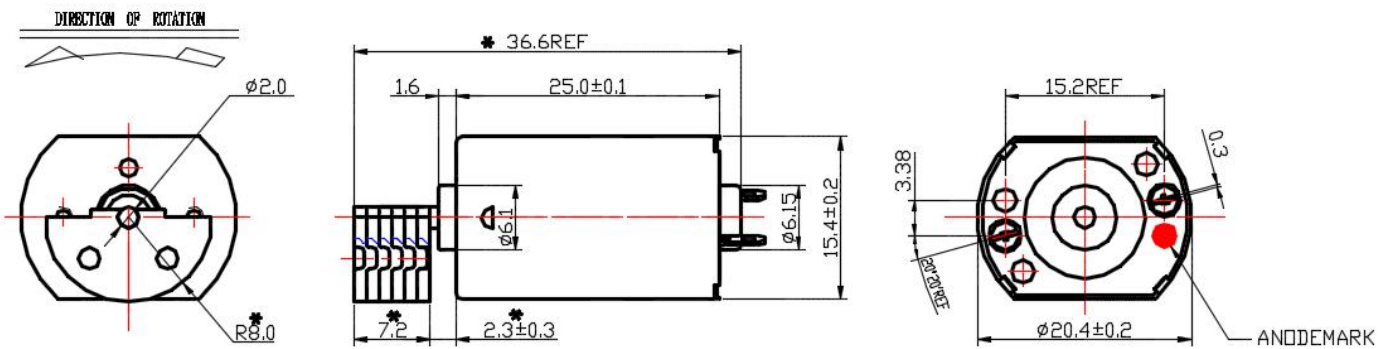

电机参数/MOTOR Data:

型号 Model	始动电压 Start voltage	额定电压 Rated voltage	负载 Load	电流 current	转速 Speed	堵转电流 Lock rotor	功率 Power
	V	V	size	A	rpm	A	W
TFF-050SH-19105	1.5	3.7	R8.0*7.2	0.88	7100	2.0	1.6
TFF-050SH-17138	1.5	3.7	R8.0*7.2	0.55	5200	1.3	1.0

可配置铁,铜,钨等材质及各种形状尺寸的偏心轮
Motor can be mounted with various shape and sizes of eccentric weight which is made of iron,brass or ferro-alloy to become vibration motor.



备注 Remarks

- 电机测试环境温度 常温 25-30℃
Ambient temperature 25-30℃
- 外型图中带*尺寸可按客户要求调整。
Dimension with * in the drawing can be adjusted according to customer's requirement.
- 可按客户要求进行性能,安装,电源连接方式,外型尺寸的设计。
Motor can be designed upon customer's requirements on performance, installation,power connection method and motor dimension.

1inch=25.4mm 1mm=0.0394inch
1g.cm=0.098mN.m 1mN.m=10.2g.cm

型号 Model: TFF-180SH

电压 Voltage: 1.5-24V

转速 Speed: 2000-30000rpm

应用领域 Application Fields: 机器人 Robots, 电子门锁 Lockset,
玩具 Toys, 家电 Appliances,
办公设备 Office equipments.



外型尺寸/DRAWING(mm)

DIRECTION OF ROTATION

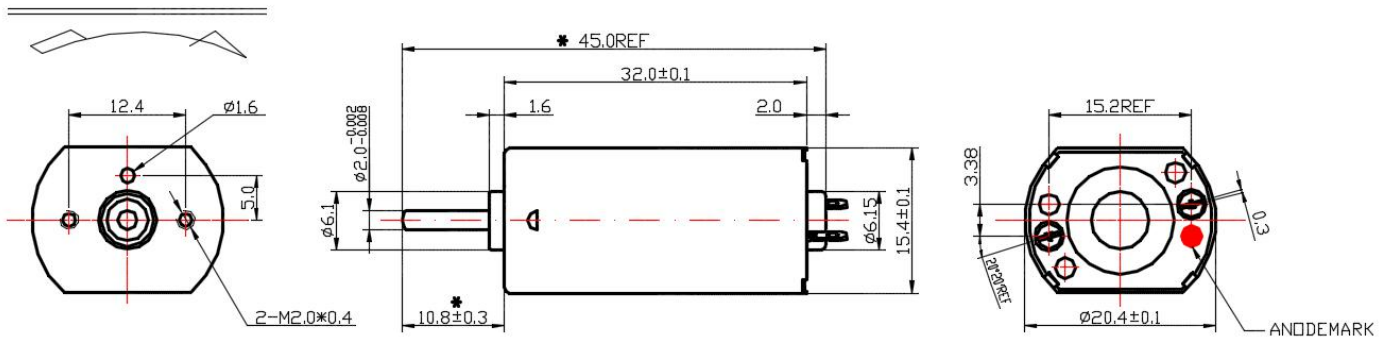

电机参数/Motor Data:

型号 Model	始动电压 Start voltage	额定电压 Rated voltage	空载转速 No Load Speed	空载电流 No Load current	负载 Load	负载转速 Load Speed	负载电流 load current	堵转力矩 Stall torque	功率 Power
	V	V	rpm	A	g.cm	rpm	A	g.cm	W
TFF-180SH-2654	1.0	3.7	11500	0.2	20	9500	0.95	100	3.3
TFF-180SH-2842	1.0	3.7	13500	0.4	10	11500	0.83	58	2.2

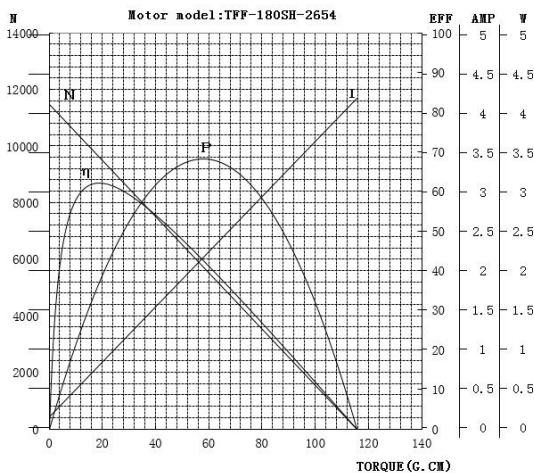

备注 Remarks

- 电机测试环境温度 常温 25-30°C
Ambient temperature 25-30°C
- 外型图中带*尺寸可按客户要求调整。
Dimension with * in the drawing can be adjusted according to customer's requirement.
- 可按客户要求进行性能,安装,电源连接方式,外型尺寸的设计。
Motor can be designed upon customer's requirements on performance, installation, power connection method and motor dimension.

1inch=25.4mm 1mm=0.0394inch
1g.cm=0.098mN.m 1mN.m=10.2g.cm

型号 Model: TRF-N15CAZ

电压 Voltage: 1.5-24V

转速 Speed: 2000-15000rpm

应用领域 Application Fields::

美容产品 Beauty Products, 成人用品 Sex toys,
按摩保健 Massage Equip, 电动牙刷 Electric toothbrush



外型尺寸/DRAWING(mm)

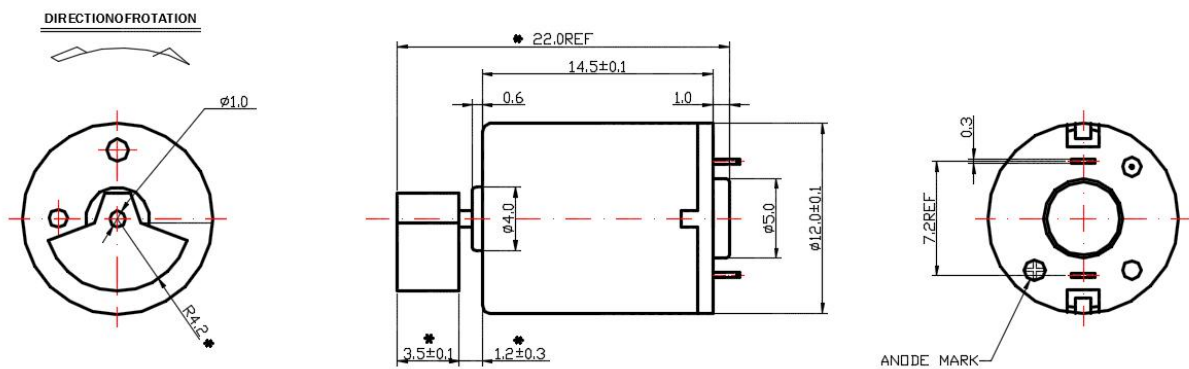

电机参数/MOTOR Data:

型号 Model	始动电压 Start voltage	额定电压 Rated voltage	负载 Load	电流 current	转速 Speed	堵转电流 Lock rotor	功率 Power
	V	V	size	A	rpm	A	W
TFF-N15CAZ-1480	1.2	3.0	φ6*7.0	0.195	12000	0.6	0.25
TFF-N15CAZ-10150	1.2	3.0	φ7*5.0	0.220	12000	0.7	0.25

可配置铁,铜,钨等材质及各种形状尺寸的偏心轮
Motor can be mounted with various shape and sizes of eccentric weight which is made of iron,brass or ferro-alloy to become vibration motor.

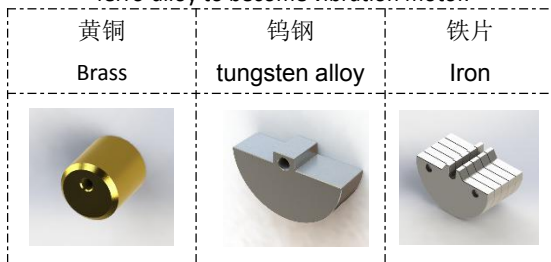

备注 Remarks

- 电机测试环境温度 常温 25-30℃
Ambient temperature 25-30℃
- 外型图中带*尺寸可按客户要求调整。
Dimension with * in the drawing can be adjusted according to customer's requirement.
- 可按客户要求进行性能,安装,电源连接方式,外型尺寸的设计。
Motor can be designed upon customer's requirements on performance, installation,power connection method and motor dimension.

1inch=25.4mm
1g.cm=0.098mN.m

1mm=0.0394inch
1mN.m=10.2g.cm

型号 Model: TRF-N25CAZ

电压 Voltage: 1.5-24V

转速 Speed: 2000-15000rpm

应用领域 Application Fields::

美容产品 Beauty Products, 成人用品 Sex toys,
按摩保健 Massage Equip, 电动牙刷 Electric toothbrush



外型尺寸/DRAWING(mm)

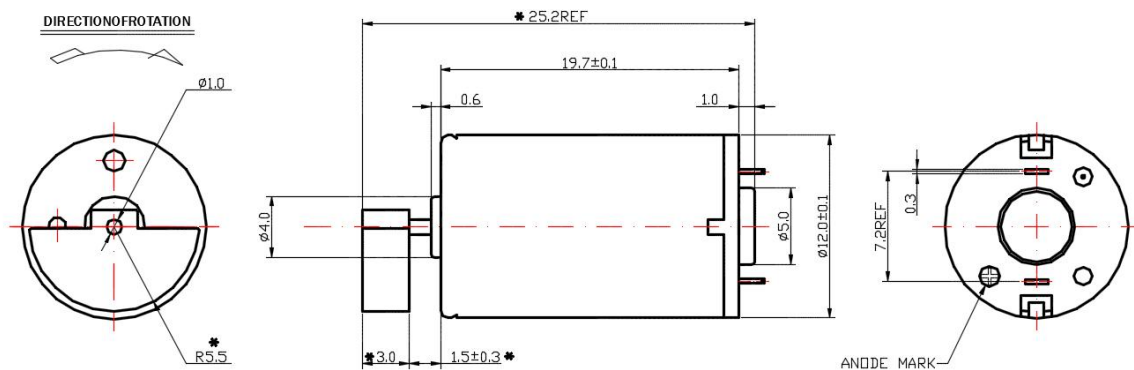

电机参数/MOTOR Data:

型号 Model	始动电压 Start voltage	额定电压 Rated voltage	负载 Load	电流 current	转速 Speed	堵转电流 Lock rotor	功率 Power
	V	V	size	A	rpm	A	W
TFF-N25CAZ-11105	1.5	3.7	R5.5*3.0	0.3	10000	0.86	0.55
TFF-N25CAZ-1295	1.2	3.7	R6*4.8	0.54	12000	1.05	0.85

可配置铁,铜,钨等材质及各种形状尺寸的偏心轮
Motor can be mounted with various shape and sizes of eccentric weight which is made of iron,brass or ferro-alloy to become vibration motor.

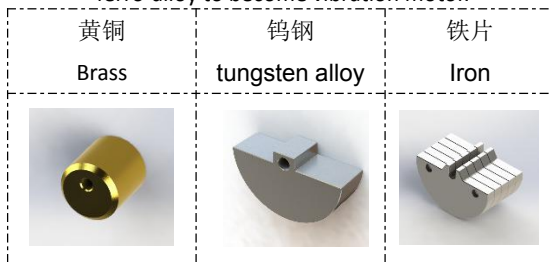

备注 Remarks

- 电机测试环境温度 常温 25-30℃
Ambient temperature 25-30℃
- 外型图中带*尺寸可按客户要求调整。
Dimension with * in the drawing can be adjusted according to customer's requirement.
- 可按客户要求进行性能,安装,电源连接方式,外型尺寸的设计。
Motor can be designed upon customer's requirements on performance, installation, power connection method and motor dimension.

1inch=25.4mm
1g.cm=0.098mN.m

1mm=0.0394inch
1mN.m=10.2g.cm

型号 Model: TRF-N25NZ

电压 Voltage: 1.5-24V

转速 Speed: 2000-15000rpm

应用领域 Application Fields::

美容产品 Beauty Products, 成人用品 Sex toys,
按摩保健 Massage Equip, 电动牙刷 Electric toothbrush



外型尺寸/DRAWING(mm)

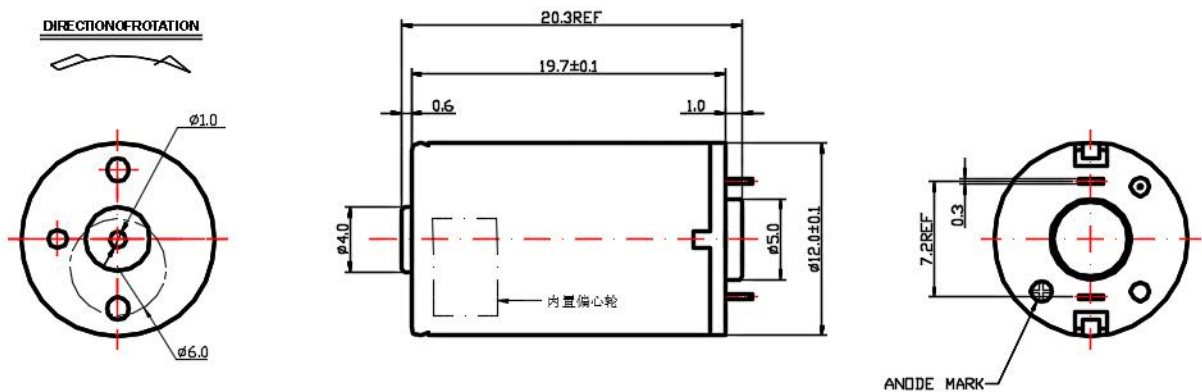

电机参数/MOTOR Data:

型号 Model	始动电压 Start voltage	额定电压 Rated voltage	负载 Load	电流 current	转速 Speed	堵转电流 Lock rotor	功率 Power
	V	V	size	A	rpm	A	W
TFF-N25NZ-09185	0.8	3.7	φ6*4.0	0.12	14000	0.9	0.2
TFF-N25NZ-	1.0	3.7	φ6*4.0	0.06	12210	0.30	0.12

可配置铁,铜,钨等材质及各种形状尺寸的偏心轮
Motor can be mounted with various shape and sizes of eccentric weight which is made of iron,brass or ferro-alloy to become vibration motor.

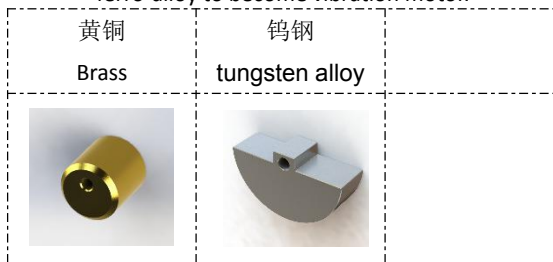

备注 Remarks

- 电机测试环境温度 常温 25-30℃
Ambient temperature 25-30℃
- 外型图中带*尺寸可按客户要求调整。
Dimension with * in the drawing can be adjusted according to customer's requirement.
- 可按客户要求进行性能,安装,电源连接方式,外型尺寸的设计。
Motor can be designed upon customer's requirements on performance, installation, power connection method and motor dimension.

1inch=25.4mm
1g.cm=0.098mN.m

1mm=0.0394inch
1mN.m=10.2g.cm

型号 Model: TFF-020CH

电压 Voltage: 1.5-24V

转速 Speed: 2000-3000rpm

应用领域 Application Fields: 机器人 Robots, 电子门锁 Lockset,
玩具 Toys, 家电 Appliances,
办公设备 Office equipments.



外型尺寸/DRAWING(mm)

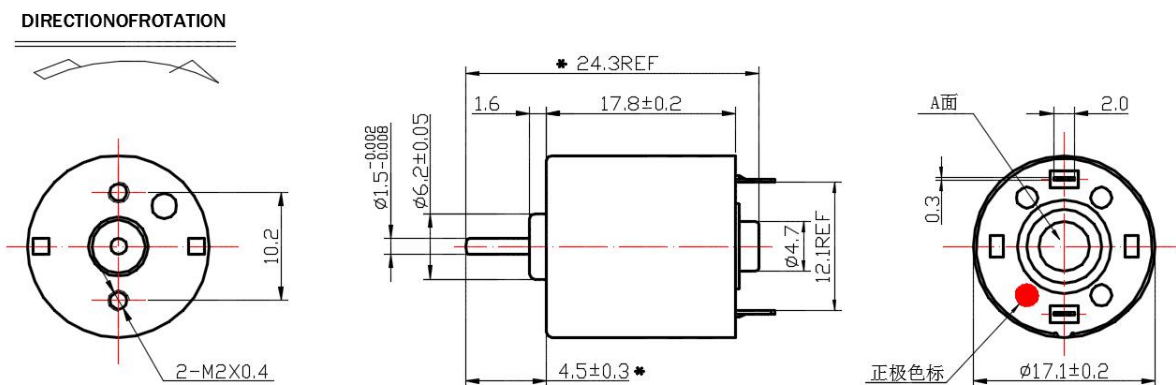

电机参数/Motor Data:

型号 Model	始动电压 Start voltage	额定电压 Rated voltage	空载转速 No Load Speed	空载电流 No Load current	负载 Load	负载转速 Load Speed	负载电流 load current	堵转力矩 Stall torque	功率 Power
	V	V	rpm	A	g.cm	rpm	A	g.cm	W
TRF-020CH-15185	1.0	4.5	12600	0.057	4.0	11500	0.153	40.0	1.38
TRF-020CH-12225	1.0	4.5	9500	0.060	10.0	6000	0.320	25.0	0.67

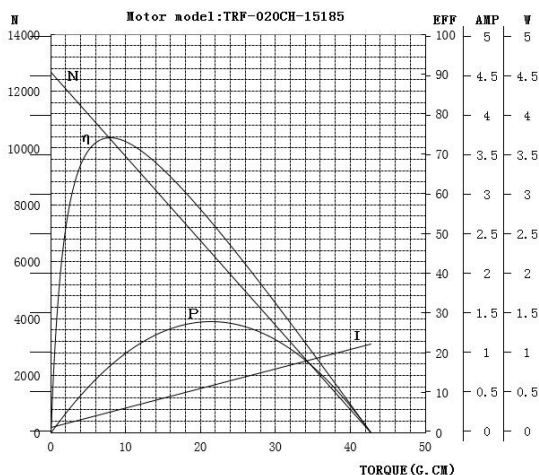

备注 Remarks

- 电机测试环境温度 常温 25-30°C
Ambient temperature 25-30°C
- 外型图中带*尺寸可按客户要求调整。
Dimension with * in the drawing can be adjusted according to customer's requirement.
- 可按客户要求进行性能,安装,电源连接方式,外型尺寸的设计。
Motor can be designed upon customer's requirements on performance, installation, power connection method and motor dimension.

1inch=25.4mm 1mm=0.0394inch
1g.cm=0.098mN.m 1mN.m=10.2g.cm

型号 Model: TRF-020CHZ

电压 Voltage: 1.5-24V

转速 Speed: 2000-15000rpm

应用领域 Application Fields::

美容产品 Beauty Products, 成人用品 Sex toys,
按摩保健 Massage Equip, 电动牙刷 Electric toothbrush



外型尺寸/DRAWING(mm)

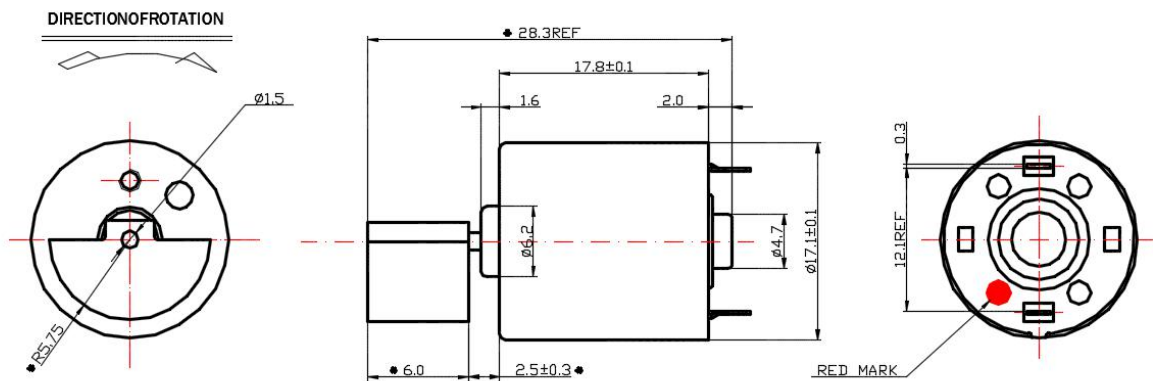

电机参数/MOTOR Data:

型号 Model	始动电压 Start voltage	额定电压 Rated voltage	负载 Load	电流 current	转速 Speed	堵转电流 Lock rotor	功率 Power
	V	V	size	A	rpm	A	W
TFF-020CHZ-15153	1.5	3.7	R5.75*6	0.5	8300	1.48	0.92
TFF-020CHZ-16145	1.5	3.7	R6.8*3.8	0.4	8200	1.7	0.86

可配置铁,铜,钨等材质及各种形状尺寸的偏心轮
Motor can be mounted with various shape and sizes of eccentric weight which is made of iron,brass or ferro-alloy to become vibration motor.

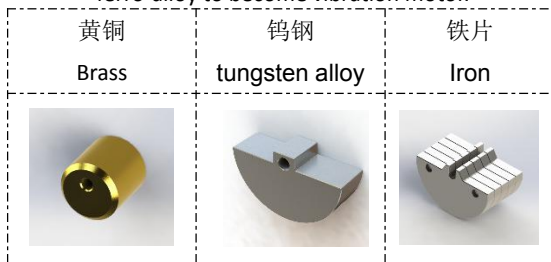

备注 Remarks

- 电机测试环境温度 常温 25-30℃
Ambient temperature 25-30℃
- 外型图中带*尺寸可按客户要求调整。
Dimension with * in the drawing can be adjusted according to customer's requirement.
- 可按客户要求进行性能,安装,电源连接方式,外型尺寸的设计。
Motor can be designed upon customer's requirements on performance, installation, power connection method and motor dimension.

1inch=25.4mm
1g.cm=0.098mN.m

1mm=0.0394inch
1mN.m=10.2g.cm

型号 Model: TRF-130CH

电压 Voltage: 1.5-24V

转速 Speed: 2000-30000rpm

应用领域 Application Fields: 机器人 Robots, 电子门锁 Lockset,
玩具 Toys, 家电 Appliances,
办公设备 Office equipments.



外型尺寸/DRAWING(mm)

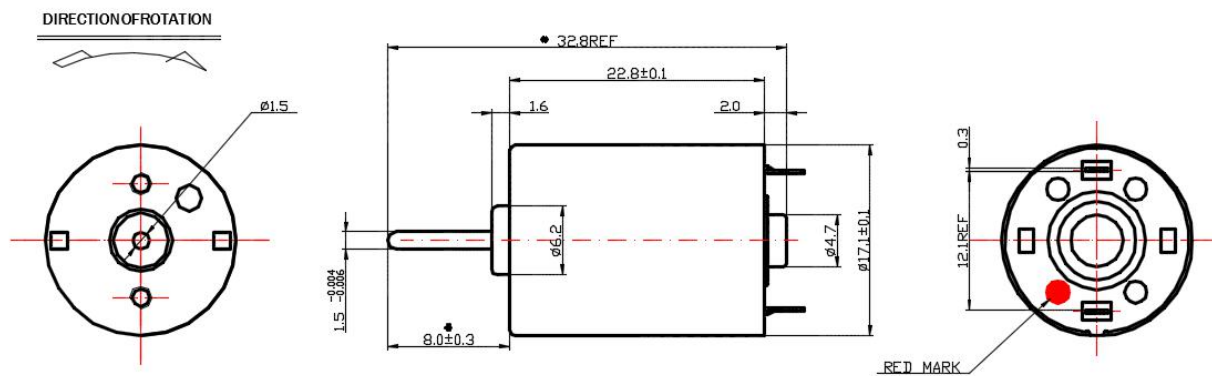

电机参数/Motor Data:

型号 Model	始动电压 Start voltage	额定电压 Rated voltage	空载转速 No Load Speed	空载电流 No Load current	负载 Load	负载转速 Load Speed	负载电流 load current	堵转力矩 Stall torque	功率 Power
	V	V	rpm	A	g.cm	rpm	A	g.cm	W
TRF-130CH-18115	0.8	3.0	8150	0.075	5.0	6980	0.23	34	0.73
TRF-130CH-13200	1.5	9.0	13500	0.1	10.0	11500	0.35	55	2.4

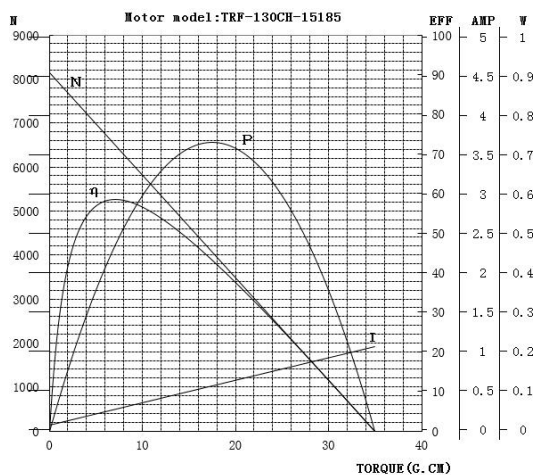

备注 Remarks

- 电机测试环境温度 常温 25-30°C
Ambient temperature 25-30°C
- 外型图中带*尺寸可按客户要求调整。
Dimension with * in the drawing can be adjusted according to customer's requirement.
- 可按客户要求进行性能,安装,电源连接方式,外型尺寸的设计。
Motor can be designed upon customer's requirements on performance, installation, power connection method and motor dimension.

1inch=25.4mm
1g.cm=0.098mN.m

1mm=0.0394inch
1mN.m=10.2g.cm

型号 Model: TRF-130CHZ

电压 Voltage: 1.5-24V

转速 Speed: 2000-15000rpm

应用领域 Application Fields::

美容产品 Beauty Products, 成人用品 Sex toys,
按摩保健 Massage Equip, 电动牙刷 Electric toothbrush



外型尺寸/DRAWING(mm)

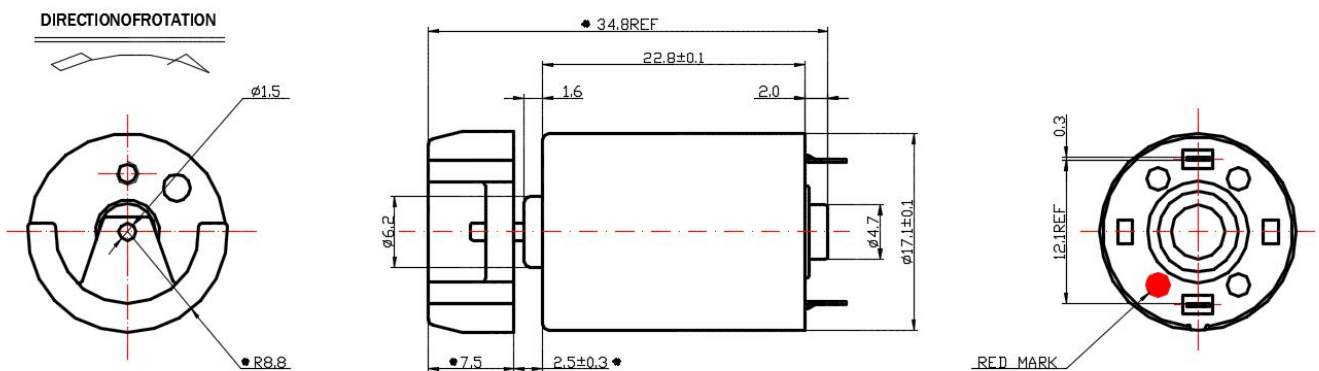

电机参数/MOTOR Data:

型号 Model	始动电压 Start voltage	额定电压 Rated voltage	负载 Load	电流 current	转速 Speed	堵转电流 Lock rotor	功率 Power
	V	V	size	A	rpm	A	W
TFF-130CHZ-18110	1.5	3.7	R8.8*7.5	0.48	7800	1.8	1.1
TFF-130CHZ-15180	1.2	3.7	R8.0*7.2	0.25	5200	0.92	0.52

可配置铁,铜,钨等材质及各种形状尺寸的偏心轮
Motor can be mounted with various shape and sizes of eccentric weight which is made of iron,brass or ferro-alloy to become vibration motor.

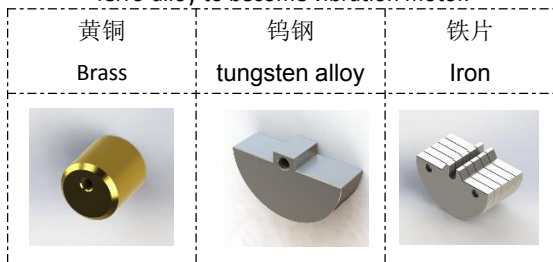

备注 Remarks

- 电机测试环境温度 常温 25-30°C
Ambient temperature 25-30°C
- 外型图中带*尺寸可按客户要求调整。
Dimension with * in the drawing can be adjusted according to customer's requirement.
- 可按客户要求进行性能,安装,电源连接方式,外型尺寸的设计。
Motor can be designed upon customer's requirements on performance, installation, power connection method and motor dimension.

1inch=25.4mm
1g.cm=0.098mN.m

1mm=0.0394inch
1mN.m=10.2g.cm

型号 Model: TRF-130NZ

电压 Voltage: 1.5-24V

转速 Speed: 2000-15000rpm

应用领域 Application Fields::

美容产品 Beauty Products, 成人用品 Sex toys,
按摩保健 Massage Equip, 电动牙刷 Electric toothbrush



外型尺寸/DRAWING(mm)

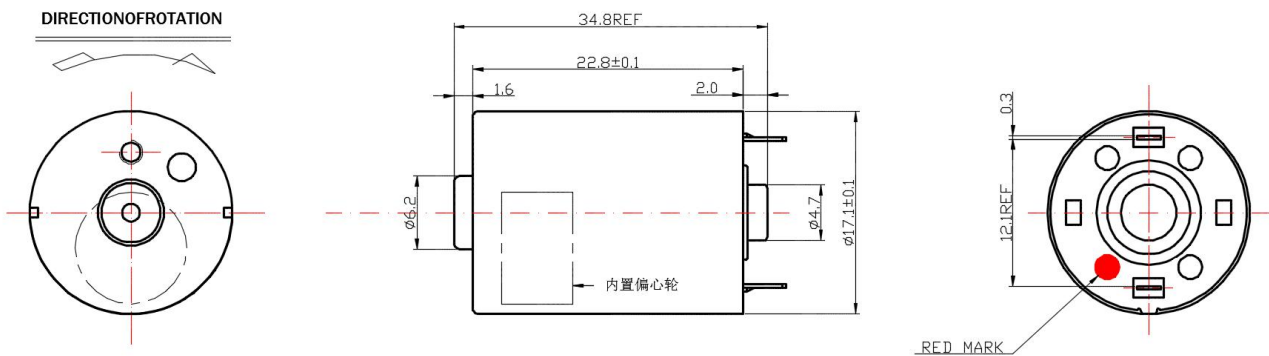

电机参数/MOTOR Data:

型号 Model	始动电压 Start voltage	额定电压 Rated voltage	负载 Load	电流 current	转速 Speed	堵转电流 Lock rotor	功率 Power
	V	V	size	A	rpm	A	W
TFF-130NZ-16120	1.0	3.7	φ8*4.0	0.38	12900	1.2	0.8

可配置铁,铜,钨等材质及各种形状尺寸的偏心轮
Motor can be mounted with various shape and sizes of eccentric weight which is made of iron, brass or ferro-alloy to become vibration motor.

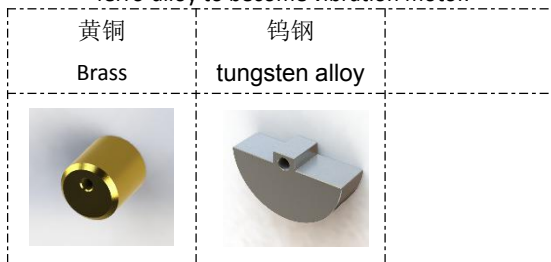

备注 Remarks

- 电机测试环境温度 常温 25-30℃
Ambient temperature 25-30℃
- 外型图中带*尺寸可按客户要求调整。
Dimension with * in the drawing can be adjusted according to customer's requirement.
- 可按客户要求进行性能,安装,电源连接方式,外型尺寸的设计。
Motor can be designed upon customer's requirements on performance, installation, power connection method and motor dimension.

1inch=25.4mm
1g.cm=0.098mN.m

1mm=0.0394inch
1mN.m=10.2g.cm

型号 Model: TRF-140SZ

电压 Voltage: 1.5-24V

转速 Speed: 2000-15000rpm

应用领域 Application Fields::

美容产品 Beauty Products, 成人用品 Sex toys,
按摩保健 Massage Equip, 电动牙刷 Electric toothbrush



外型尺寸/DRAWING(mm)

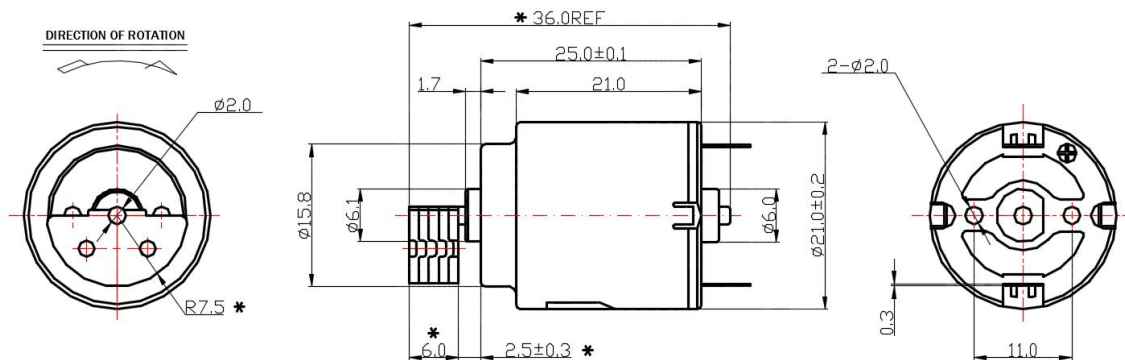

电机参数/MOTOR Data:

型号 Model	始动电压 Start voltage	额定电压 Rated voltage	负载 Load	电流 current	转速 Speed	堵转电流 Lock rotor	功率 Power
	V	V	size	A	rpm	A	W
TFF-140SZ-10340	2.5	7.4	R7.5*6.0	0.15	5400	0.4	0.83
TFF-140SZ-2092	1.2	3.0	R8.0*7.2	0.78	6950	2.0	1.6

可配置铁,铜,钨等材质及各种形状尺寸的偏心轮
Motor can be mounted with various shape and sizes of eccentric weight which is made of iron,brass or ferro-alloy to become vibration motor.

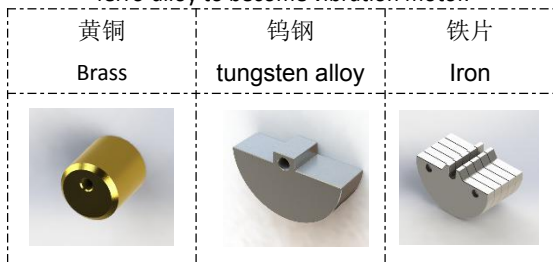

备注 Remarks

- 电机测试环境温度 常温 25-30℃
Ambient temperature 25-30℃
- 外型图中带*尺寸可按客户要求调整。
Dimension with * in the drawing can be adjusted according to customer's requirement.
- 可按客户要求进行性能,安装,电源连接方式,外型尺寸的设计。
Motor can be designed upon customer's requirements on performance, installation,power connection method and motor dimension.

1inch=25.4mm 1mm=0.0394inch
1g.cm=0.098mN.m 1mN.m=10.2g.cm

型号 Model: TRF-370CH

电压 Voltage: 1.5-24V

转速 Speed: 2000-30000rpm

应用领域 Application Fields: 机器人 Robots, 电子门锁 Lockset,
玩具 Toys, 家电 Appliances,
办公设备 Office equipments.



外型尺寸/DRAWING(mm)

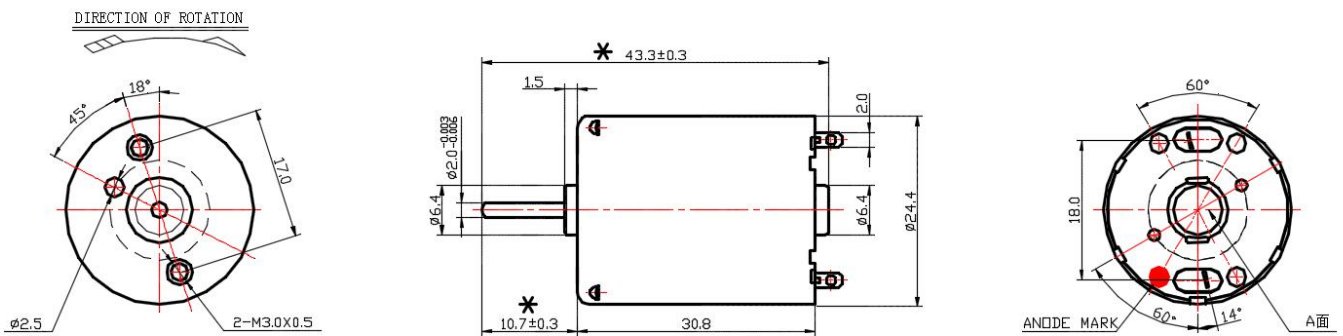

电机参数/Motor Data:

型号 Model	始动电压 Start voltage	额定电压 Rated voltage	空载转速 No Load Speed	空载电流 No Load current	负载 Load	负载转速 Load Speed	负载电流 load current	堵转力矩 Stall torque	功率 Power
	V	V	rpm	A	g.cm	rpm	A	g.cm	W
TRF-370CH-2865	1.5	3.7	9000	0.18	20.0	7600	0.75	110	2.95
TRF-370CH-15330	1.5	12	4780	0.03	40	3820	0.17	200	2.2

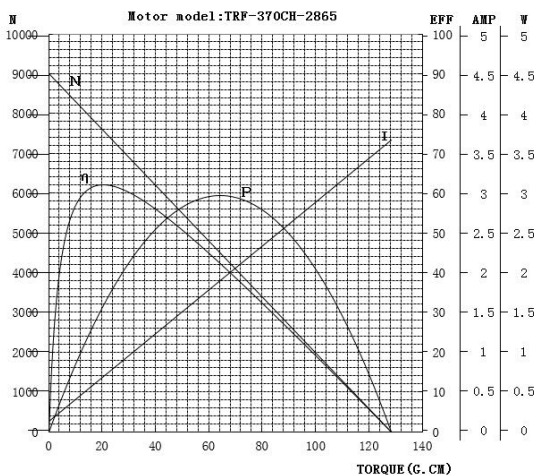

备注 Remarks

- 电机测试环境温度 常温 25-30°C
Ambient temperature 25-30°C
- 外型图中带*尺寸可按客户要求调整。
Dimension with * in the drawing can be adjusted according to customer's requirement.
- 可按客户要求进行性能,安装,电源连接方式,外型尺寸的设计。
Motor can be designed upon customer's requirements on performance, installation, power connection method and motor dimension.

1inch=25.4mm
1g.cm=0.098mN.m

1mm=0.0394inch
1mN.m=10.2g.cm

型号 Model: TFF-N20GM12F

电压 Voltage: 1.5-24V

转速 Speed: 2000-3000rpm

应用领域 Application Fields: 机器人 Robots, 电子门锁 Lockset,
玩具 Toys, 家电 Appliances,
办公设备 Office equipments.



外型尺寸/DRAWING(mm)

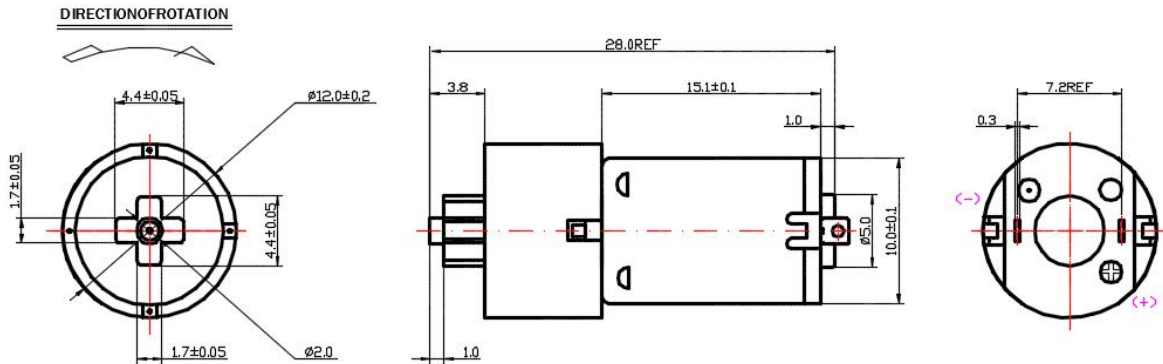

电机参数/Motor Data:

型号 (速比) Model(reduction ratio)	始动电压 Start voltage	额定电压 Rated voltage	空载转速 No Load Speed	空载电流 No Load current	负载 Load	负载转速 Load Speed	负载电流 load current	堵转力矩 Stall torque	功率 Power
	V	V	rpm	A	g.cm	rpm	A	g.cm	W
TF-GM12F N20-11110(1:120)	0.8	3.7	160	0.065	360	143	0.26	2000	1.4
TF-GM12F N20-1390(1:120)	1.2	3.7	193	0.09	366	150	0.28	2000	1.24

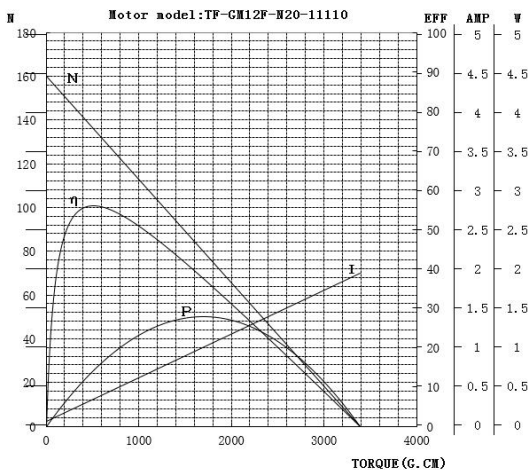

备注 Remarks

- 电机测试环境温度 常温 25-30°C
Ambient temperature 25-30°C
- 外型图中带*尺寸可按客户要求调整。
Dimension with * in the drawing can be adjusted according to customer's requirement.
- 可按客户要求进行性能,安装,电源连接方式,外型尺寸的设计。
Motor can be designed upon customer's requirements on performance, installation, power connection method and motor dimension.

1inch=25.4mm 1mm=0.0394inch
1g.cm=0.098mN.m 1mN.m=10.2g.cm

