

REV.	ECN NO./DESCRIPTION	DATE
B	RD19063	2020.06.15

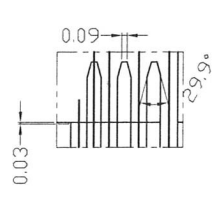

- 注：
1. 所有磨床拐角處清角R<0.03
  2. 所有放電拐角處清角R<0.04
  3. 未標尺寸的射按圖紙參考3D加工.
  4. 放電火花紋需一致R值為0.40.

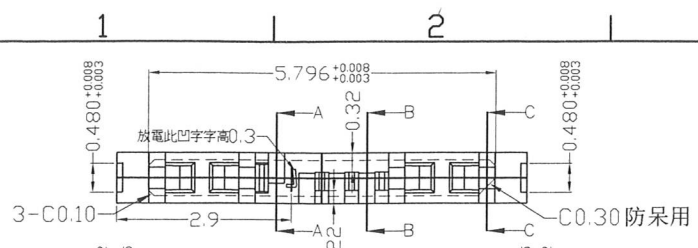
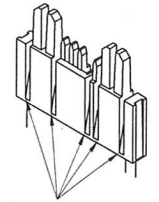

兩側槽清角R<0.02mm

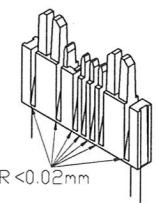

兩側槽清角R<0.02mm

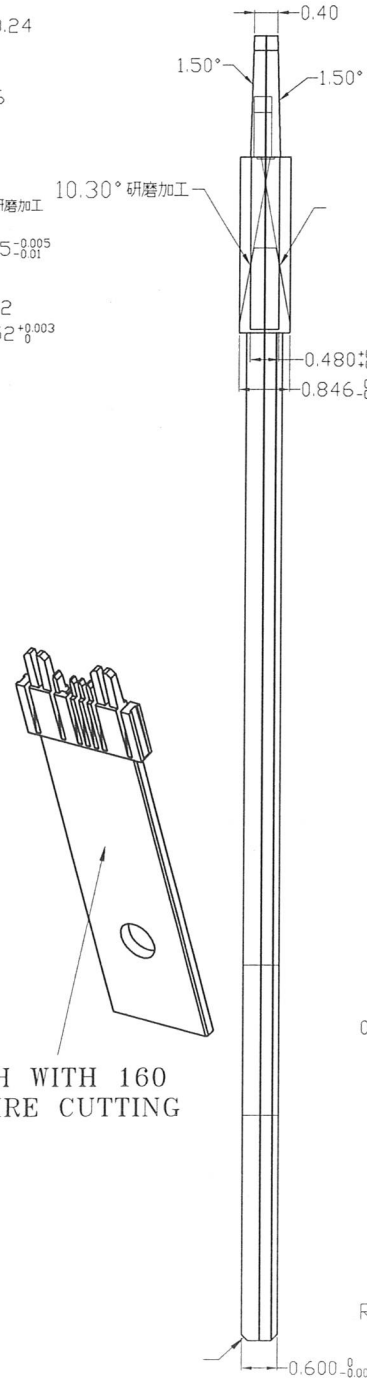
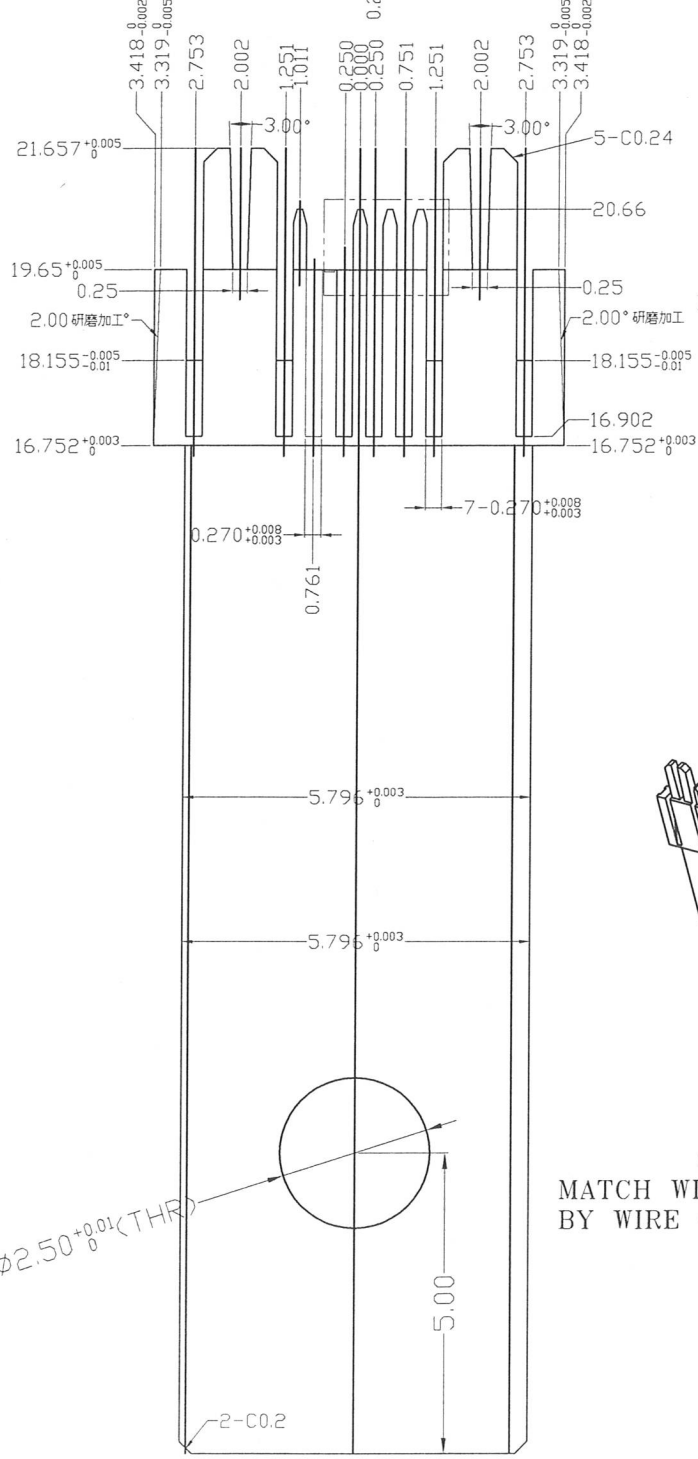
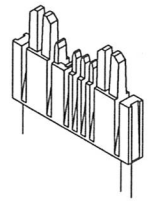

MATCH WITH 160 BY WIRE CUTTING

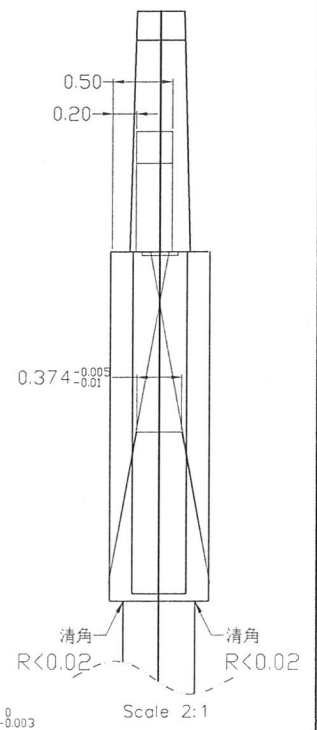

$\phi 2.50^{+0.01}(\text{THR})$

GENERAL TOLERANCES UNLESS SPECIFIED		MATERIAL ASSAB Viking(超深冷處理)	PART NO. ABA-USB-870-P01		CAYMAN MOULD TECHN. CO.,LTD		
LINEAR	ANGLE	FINISH HRC52~54°	APPROVED BY		TITLE 任天堂直焊TYPE C PLUG主體 母模機件		
.X ±0.05	X.°±1°		CHECKED BY		DWG NO. 161		
.XX ±0.01	.X.°±0.5°	UNITS MM	DRAWN BY BILL		SHEET 1/2	SCALE 1:0.13	REV B
.XXX ±0.005	.XX.°±0.1°	SIZE A4	Q'TY 8	2020.06.15			
.XXXX ±0.002	.XXX.°±0.05°						